

User's Manual

MDS-T261

TiltStand

Thank you very much for choosing an EIZO product.

Please read this User's Manual carefully to familiarize you with safe and effective usage procedures.

Please retain this manual for future reference.

PRECAUTIONS

● IMPORTANT

- To personal safety and proper maintenance, please read carefully this section.

CAUTION

Ask an installation contractor to perform installation.

Never attempt installation yourself because doing so may result in injury or equipment damage.

Attach only to specified EIZO LCD monitors.

Attachment to an unsupported EIZO monitor may cause the monitor to fall off and result in injury or equipment damage.

For information on supported monitors, visit our web site. (<http://www.eizoglobal.com>)

Always install the stand securely.

Failure to install the stand securely may cause the monitor to come off or fall down and result in injury or equipment damage.

Before installation, check that the desk or wall for securing the stand is strong enough. If any bolts or screws come loose during use, retighten them.

The stand must be attached and installed by at least two people.

Otherwise, the monitor may fall resulting in injury or equipment damage.

Place the unit on a sturdy and stable place.

Installation on an unstable surface may cause the monitor to fall down and result in injury or equipment damage.

Do not lean against the stand.

Doing so may result in personal injury or equipment damage.



Refer all servicing to qualified service personnel.

Do not attempt to service this product yourself as opening or removing covers may result in fire, electric shock, or equipment damage.



Package Contents

- Stand parts

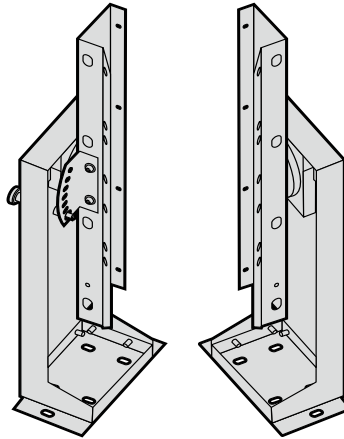

- User's Manual (this manual)
- Bolt: M6 x 14 (6 pcs)
- Screw: M3 x 10 (8 pcs)

Note

- Bolts used to fasten the stands to inboard facilities are not provided.
-

Installation

1. Lay the LCD monitor on a soft cloth spread over on a stable surface with the panel surface facing down.

2. Install the stands on the back panel of the monitor.

1. Remove the eight screws from the back panel of the monitor.

- Tool required: Phillips screwdriver (#2)

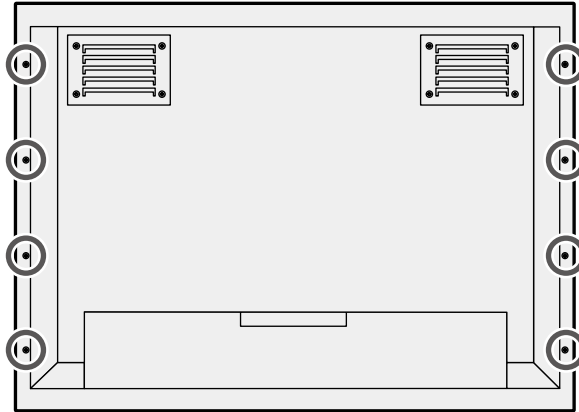

2. Fasten one of the stands by screwing the included screws and bolts into the seven screw holes in the back panel of the monitor.

Screw: M3 x 10
Screw tightening torque: 0.6 N·m - 1.0 N·m
Tool required: Phillips screwdriver (#2)

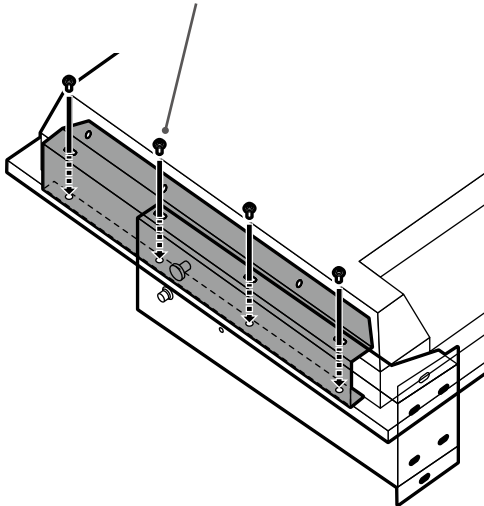

Bolt: M6×14
Screw tightening torque: 8.7 N·m - 9.7 N·m
Tools required: Hex key (5 mm)

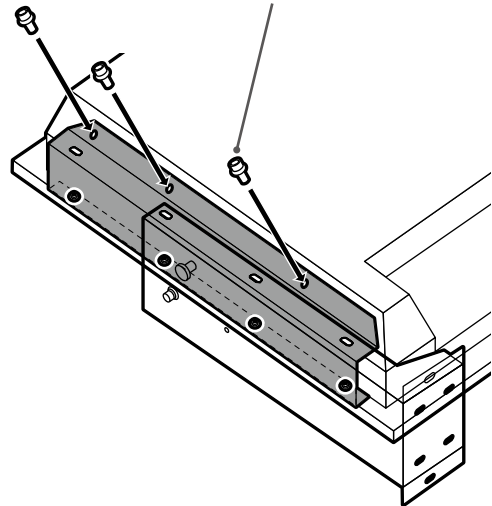

3. Fasten the other stand in the same way.

3. Fasten the stands to an inboard facility.

Attention

- Always perform this task with two or more people.

Note

- Bolts used to fasten the stands to inboard facilities are not provided. Prepare bolts that are suitable for the installation location in advance.
- Conditions for installing the stands on an inboard facility are as follows:
 - Dimensions of mounting holes

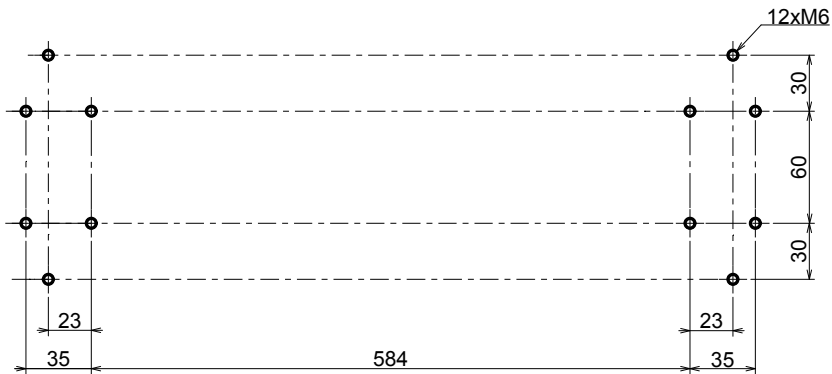

- Mounting face
Horizontal plane with a flatness error of 2 mm or less.

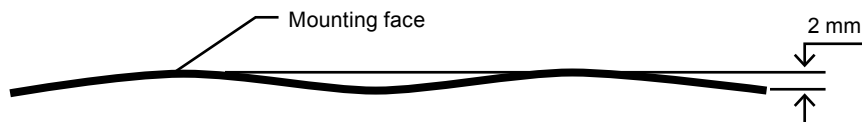

- The recommended bolt specifications are shown below:
 - Quantity : 12 pcs
 - Size : M6
 - Tensile strength ranking : 10 or more
- The tightening torque and the required tool are as follows:
 - Screw tightening torque: 8.7 N·m - 9.7 N·m
 - Tools required: Hex key (5 mm)

1. Two people must hold the monitor with the stand attached.

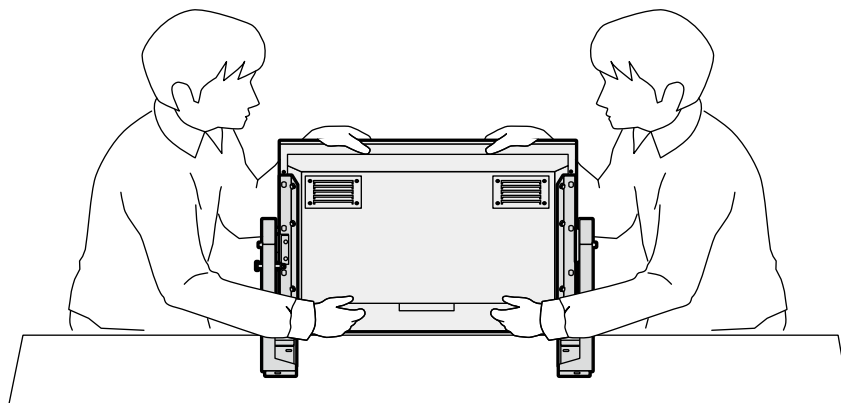

- Align the mounting holes in the inboard facility with those in the stand bases.
- Using the bolts, fasten the left and right stands to the inboard facility at two positions.

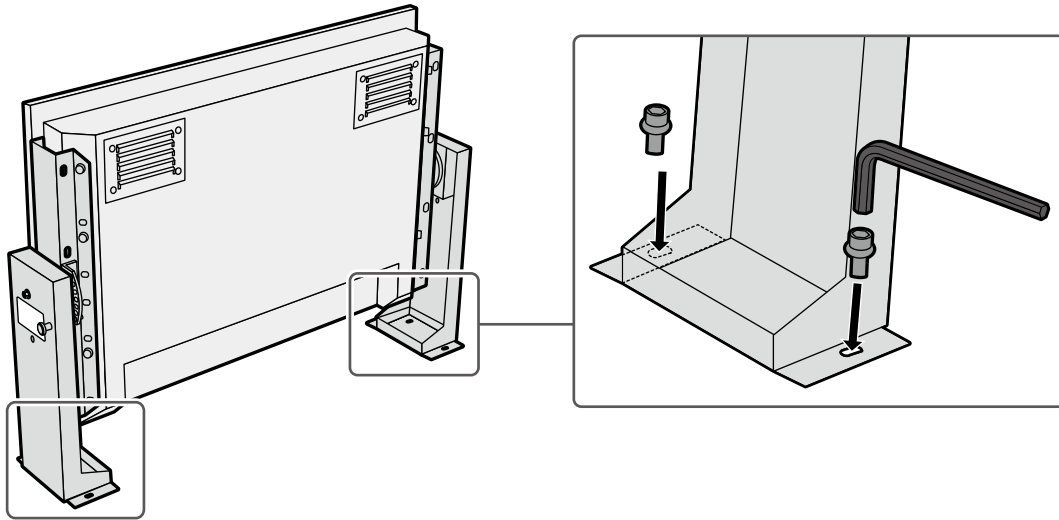

- Tilt the monitor while pulling the tilt lock pin. Refer to "Angle Adjustment" (page 7) for details about how to tilt the monitor.
- Using the bolts, securely fasten the left and right stands to the inboard facility at four positions.

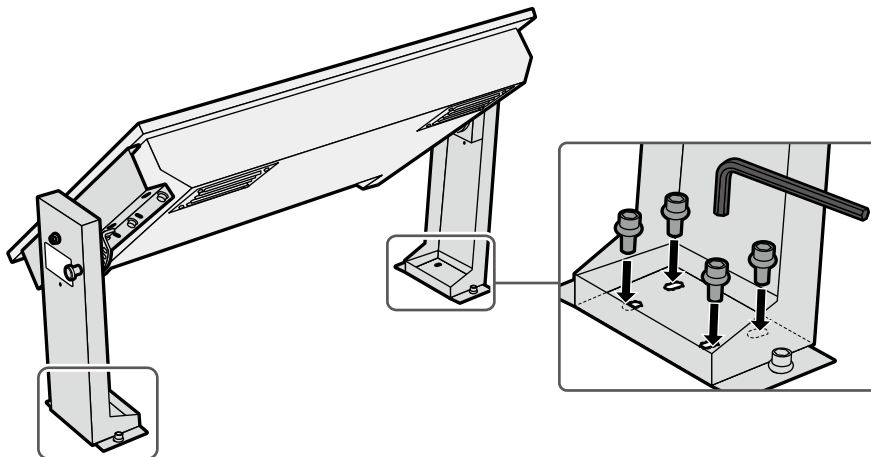

- From the left and right stands, remove each detachment prevention screw.

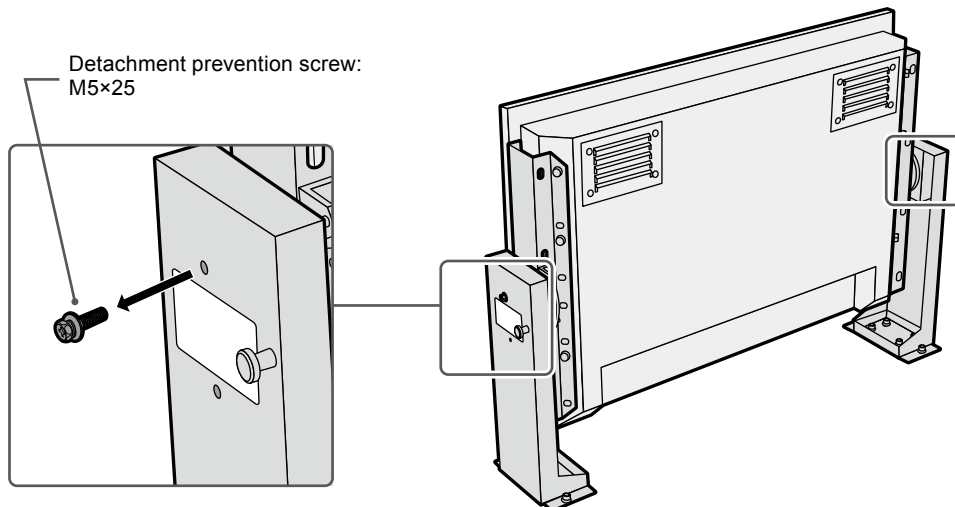

Attention

- Vibration resistance does not work unless the detachment prevention screws are removed. Be sure to remove the screws so that the vibration resistance function works appropriately.
- Be sure to store the detachment prevention screws in a designated location. They are necessary when removing the monitor from the inboard facility.
- The detachment prevention screws that have been removed must be kept in the locations shown in the illustration so that they will not be lost.

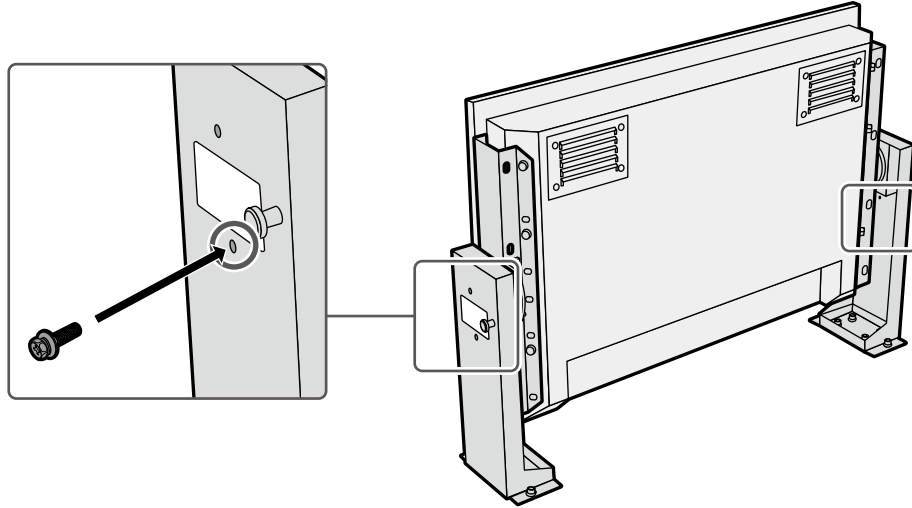

Detachment

1. To detach the stands, perform the installation procedure in reverse.

Attention

- Before you detach the stands from the inboard facility, be sure to install the detachment prevention screws to their original positions (with a tightening torque: 0.1 N·m to 0.2 N·m). Note that if the detachment prevention screws are not installed correctly, the monitor or stands may drop during operation.

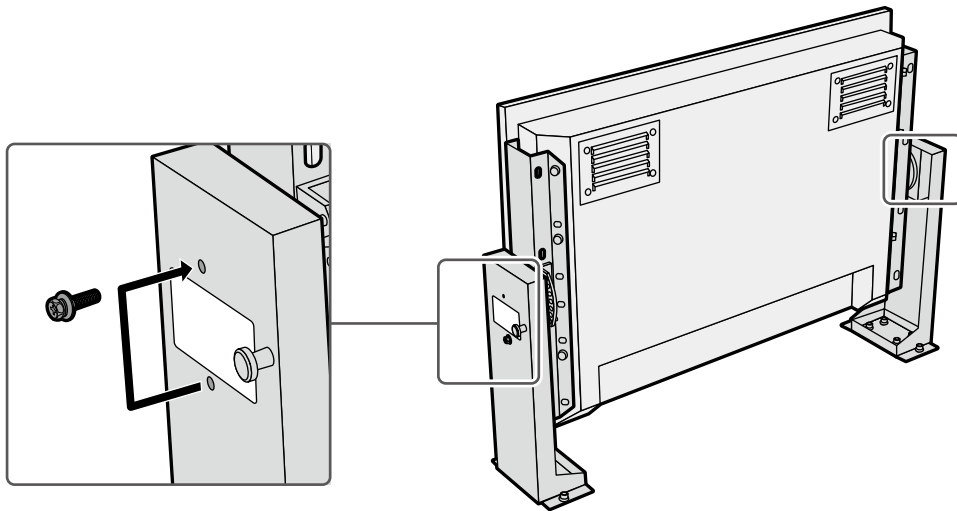

Angle Adjustment

Attention

- Be careful not to pinch your fingers when adjusting the stand.

1. Hold the upper or lower monitor bezel to support the monitor, and pull the tilt lock pin out.

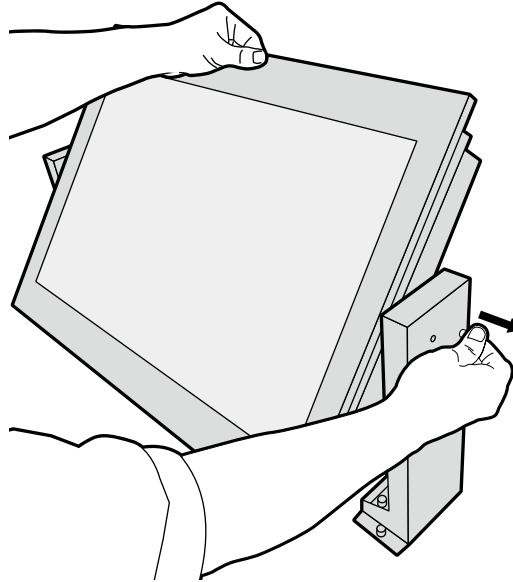

2. Adjust the angle and secure the monitor using the tilt lock pin.

Maintenance

After installation, regularly check the product to ensure that no screws and bolts are loose.

Specifications

Weight (including screws and bolts)		Approx.4.4 kg
Tilt		0° to 60° (in increments of 10°)
Operating Environmental Requirements	Temperature	-15 °C - 55 °C (5 °F - 131 °F)
	Humidity	10 % - 90 %

Outside dimensions (when the monitor is installed)

Unit: mm

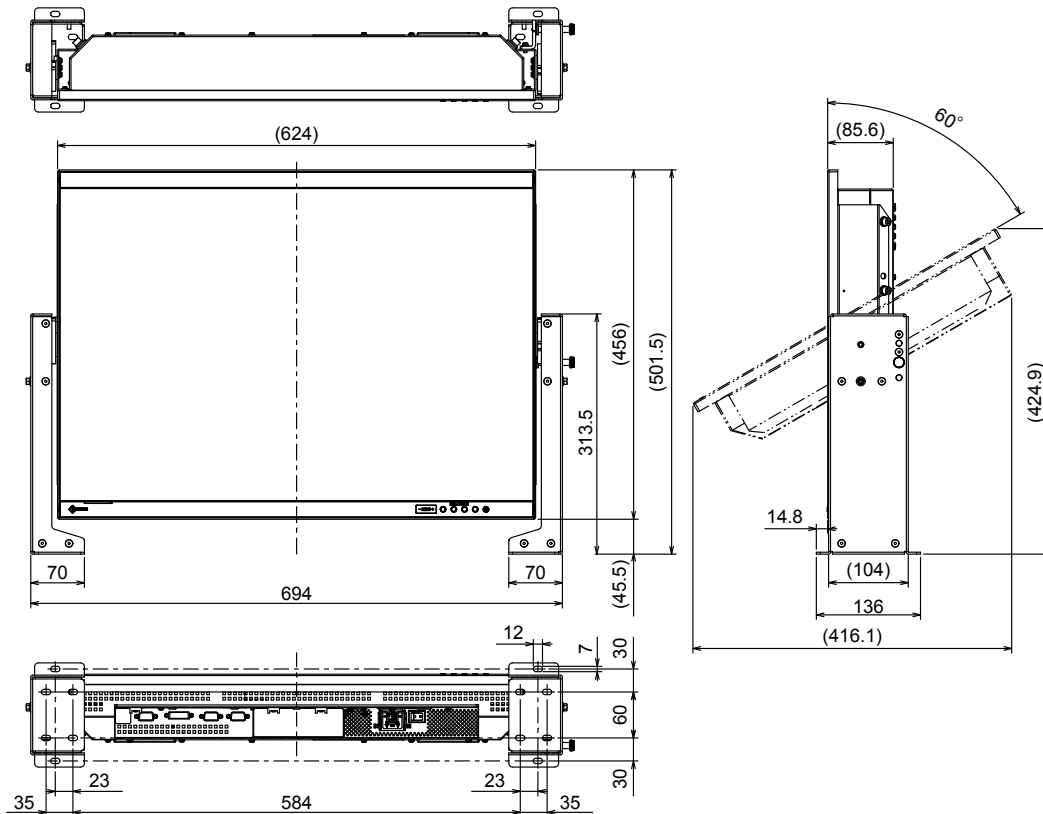

LIMITED WARRANTY

EIZO Corporation (hereinafter referred to as “**EIZO**”) and distributors authorized by EIZO (hereinafter referred to as the “**Distributors**”) warrant, subject to and in accordance with the terms of this limited warranty (hereinafter referred to as the “**Warranty**”), to the original purchaser (hereinafter referred to as the “**Original Purchaser**”) who purchased the product specified in this document (hereinafter referred to as the “**Product**”) from EIZO or Distributors, that EIZO and Distributors shall, at their sole discretion, either repair or replace the Product at no charge if the Original Purchaser becomes aware within the Warranty Period (defined below) that the Product malfunctions or is damaged in the course of normal use of the Product in accordance with the description in the instruction manual attached to the Product (hereinafter referred to as the “**User’s Manual**”).

The period of this Warranty is two (2) years from the date of purchase of the Product (hereinafter referred to as the “**Warranty Period**”). EIZO and Distributors shall bear no liability or obligation with regard to the Product in relation to the Original Purchaser or any third parties other than as provided under this Warranty.

EIZO and Distributors will cease to hold or store any parts (excluding design parts) of the Product upon expiration of ten (10) years after the production of the Product is discontinued. In repairing the monitor, EIZO and Distributors will use renewal parts which comply with our QC standards. If the unit cannot be repaired due to its condition or the stockout of a relevant part, EIZO and Distributors may offer the replacement by a product with equivalent performance instead of repairing it.

The Warranty is valid only in the countries or territories where the Distributors are located. The Warranty does not restrict any legal rights of the Original Purchaser.

Notwithstanding any other provision of this Warranty, EIZO and Distributors shall have no obligation under this Warranty whatsoever in any of the cases as set forth below:

- (a) Any defect of the Product caused by freight damage, modification, alteration, abuse, misuse, accident, incorrect installation, disaster, faulty maintenance and/or improper repair by third party other than EIZO and Distributors;
- (b) Any incompatibility of the Product due to possible technical innovations and/or regulations;
- (c) Any deterioration of the sensor;
- (d) Any defect of the Product caused by external equipment;
- (e) Any defect of the Product on which the original serial number has been altered or removed;
- (f) Any normal deterioration of the product, particularly that of consumables, accessories, and/or attachments (e.g. buttons, rotating parts, cables, User’s Manual, etc.);
- (g) Any deformation, discoloration, and/or warp of the exterior of the product including that of the surface of the LCD panel;
- (h) Any defect of the Product caused by placement in a location where it may be affected by strong vibration or shocks;
- (i) Any defect of the Product caused by liquid leaking from battery; and
- (j) Any deterioration of display performance caused by the deterioration of expendable parts such as the LCD panel and/or backlight, etc. (e.g. changes in brightness, changes in brightness uniformity, changes in color, changes in color uniformity, defects in pixels including burnt pixels, etc.).

To obtain service under the Warranty, the Original Purchaser must deliver the Product, freight prepaid, in its original package or other adequate package affording an equal degree of protection, assuming the risk of damage and/or loss in transit, to the local Distributor. The Original Purchaser must present proof of purchase of the Product and the date of such purchase when requesting services under the Warranty.

The Warranty Period for any replaced and/or repaired product under this Warranty shall expire at the end of the original Warranty Period.

EIZO OR DISTRIBUTORS ARE NOT RESPONSIBLE FOR ANY DAMAGE TO, OR LOSS OF, DATA OR OTHER INFORMATION STORED IN ANY MEDIA OR ANY PART OF ANY PRODUCT RETURNED TO EIZO OR DISTRIBUTORS FOR REPAIR.

EIZO AND DISTRIBUTORS MAKE NO FURTHER WARRANTIES, EXPRESSED OR IMPLIED, WITH RESPECT TO THE PRODUCT AND ITS QUALITY, PERFORMANCE, MERCHANTABILITY OR FITNESS FOR ANY PARTICULAR USE. IN NO EVENT SHALL EIZO OR DISTRIBUTORS BE LIABLE FOR ANY INCIDENTAL, INDIRECT, SPECIAL, CONSEQUENTIAL OR OTHER DAMAGE WHATSOEVER (INCLUDING, WITHOUT LIMITATION, DAMAGES FOR LOSS OF PROFIT, BUSINESS INTERRUPTION, LOSS OF BUSINESS INFORMATION, OR ANY OTHER PECUNIARY LOSS) ARISING OUT OF THE USE OR INABILITY TO USE THE PRODUCT OR IN ANY CONNECTION WITH THE PRODUCT, WHETHER BASED ON CONTRACT, TORT, NEGLIGENCE, STRICT LIABILITY OR OTHERWISE, EVEN IF EIZO OR DISTRIBUTORS HAVE BEEN ADVISED OF THE POSSIBILITY OF SUCH DAMAGES. THIS EXCLUSION ALSO INCLUDES ANY LIABILITY WHICH MAY ARISE OUT OF THIRD PARTY CLAIMS AGAINST THE ORIGINAL PURCHASER. THE ESSENCE OF THIS PROVISION IS TO LIMIT THE POTENTIAL LIABILITY OF EIZO AND DISTRIBUTORS ARISING OUT OF THIS LIMITED WARRANTY AND/OR SALES.

EIZO Corporation

153 Shimokashiwano, Hakusan, Ishikawa 924-8566 Japan

EIZO Europe GmbH

Helmut-Grashoff-Strasse 18, 41179 Mönchengladbach, Germany

艺卓显像技术(苏州)有限公司

中国苏州市苏州工业园区展业路 8 号中新科技工业坊 5B



EIZO株式会社

〒 924-8566 石川県白山市下柏野町 153 番地

<http://www.eizo.co.jp>

<http://www.eizoglobal.com>

Copyright © 2017 EIZO Corporation. All rights reserved.

00N0N021A1 
UM-MDS-T261-AL 

1st Edition-September, 2017 Printed in Japan.