



Installation Manual

RadiForce® GX570

Monochrome LCD Monitor

Important

To ensure that the product is used correctly, carefully read through this Installation Manual and the Instructions for Use before use.

- See the Instructions for Use for monitor installation and connection.
- You can check the latest product information, including the Installation Manual, from our web site.
www.eizoglobal.com

This product has been adjusted specifically for use in the region to which it was originally shipped.
If operated outside this region, the product may not perform as stated in the specifications.

No part of this manual may be reproduced, stored in a retrieval system, or transmitted, in any form or by any means, electronic, mechanical, or otherwise, without the prior written permission of EIZO Corporation.

EIZO Corporation is under no obligation to hold any submitted material or information confidential unless prior arrangements are made pursuant to EIZO Corporation's receipt of said information. Although every effort has been made to ensure that this manual provides up-to-date information, please note that EIZO product specifications are subject to change without notice.

CONTENTS

1 Basic Adjustment / Settings	4
1.1 Switch Operation Method	4
1.2 Switching Input Signals	5
1.3 Switching Display Mode (CAL Switch Mode)	5
1.3.1 CAL switch modes	5
1.4 Switching PCs Used to Operate USB Devices	6
2 Advanced Adjustments/Settings	7
2.1 Basic Operation of the Setting Menu	7
2.2 Setting Menu Functions	8
2.2.1 CAL Switch Mode	8
2.2.2 RadiCS SelfQC	10
2.2.3 Preferences	15
2.2.4 Languages	17
2.2.5 Information	17
3 Administrator Settings	18
3.1 Basic Operations of the "Administrator Settings" Menu	18
3.2 Functions of the "Administrator Settings" Menu	18
4 Troubleshooting	21
4.1 No Picture	21
4.2 Imaging Problems	22
4.3 Other Problems	23
4.4 Error Code Table	24
5 Reference	25
5.1 Arm Installation Procedure	25
5.2 Using the USB Hub Function	27
5.3 Main Default Settings	28
5.3.1 CAL Switch Mode	28
5.3.2 Others	28
Appendix	29
Trademark	29
License	29
LIMITED WARRANTY	30

1 Basic Adjustment / Settings

This chapter mainly describes the basic functions that can be adjusted and set using the switches on the front of the monitor.

For advanced adjustment and setting procedures using the Setting menu, see [2 Advanced Adjustments/Settings ▶ 7](#)].



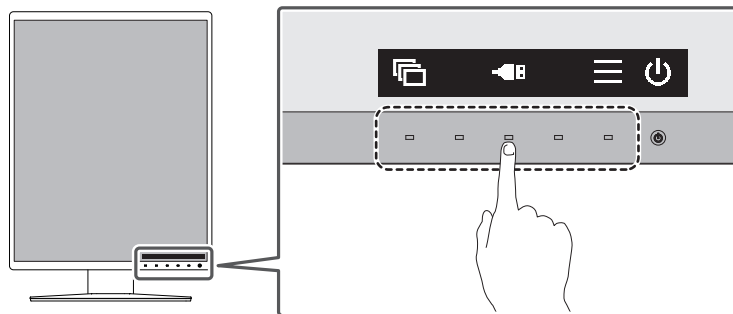

1.1 Switch Operation Method

1. Touch any switch (except )
The operation guide appears on the screen.









Note

- Do not directly touch the operation guide that appears on the screen. There are switches below the operation guide that can be touched to perform adjustment/setting.

2. Touch a switch for adjustment/setting.
The Adjustment / Setting menu appears.
(A sub menu may also be displayed. In this case, select the item for adjustment/setting using   and select .)
3. Perform adjustment/setting with the switches and select  to accept the changes.
4. Select  to exit the menu.

1.2 Switching Input Signals

When a monitor has multiple signal inputs, the signal to display on-screen can be changed.

1. Select .
The Setting menu appears.
2. Select "Preferences" from the Setting menu, then select .
3. Select "Input" and then .
4. Use  or  to select either "DisplayPort 1," "DisplayPort 2," or "DVI" and then select .

When the setting is complete, the input port names appear.

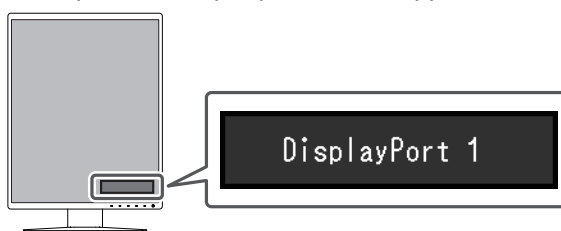

Attention

- If you turn the main power off and on again, the input signal is automatically detected regardless of the setting.
- If the PC that outputs the specified signal enters the power saving mode or is turned off when "Auto Input Detection" is set to "On," any other available signal is displayed automatically (refer to [Auto Input Detection \[▶ 15\]](#)).

1.3 Switching Display Mode (CAL Switch Mode)

The display mode can be selected according to the monitor application.

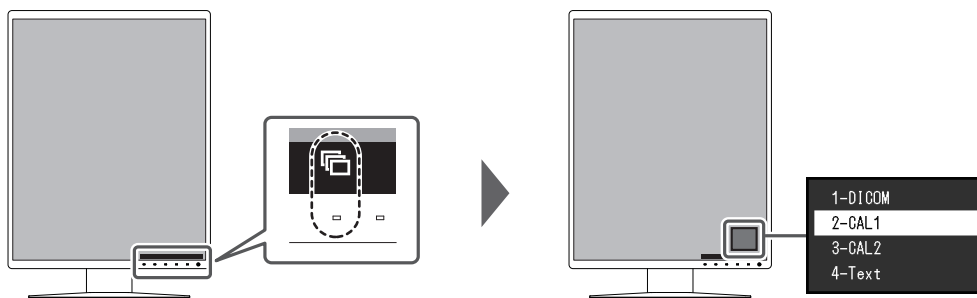

1.3.1 CAL switch modes



✓: Can be calibrated

Mode	Purpose	
1-DICOM	Enables display using DICOM® Part 14-compliant grayscale characteristics.	✓
2-CAL1	Displays the calibration status using calibration software.	✓
3-CAL2		✓
4-Text	Suitable to display documents, spreadsheets, or other text.	-

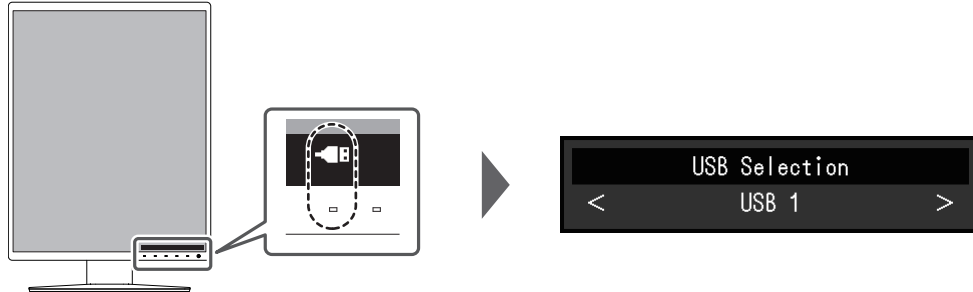

1.4 Switching PCs Used to Operate USB Devices

Select the PC that will operate USB peripherals such as a mouse and keyboard connected to the USB downstream port of the monitor.



- "USB 1"
The PC connected to USB-B 1 () is selected.
- "USB 2"
The PC connected to USB-B 2 () is selected.

Attention

-  does not display by default. To display it, you need to change the settings. For more information, see [USB Selection](#) [▶ 16].
- Switching the USB upstream port will temporarily disconnect the USB signal. If a storage device such as a USB memory stick is connected to the monitor, switch the port only after you have removed the storage device.
- Connect a PC to USB-B 1 () to perform monitor quality control.

Note





- The PCs that use USB devices can be switched in connection with the switching of input signals or the mouse position by using RadiCS / RadiCS LE (Switch-and-Go). For details, refer to the Instructions for Use for RadiCS / RadiCS LE.

2 Advanced Adjustments/Settings

This chapter describes the advanced monitor adjustment and setting procedures using the Setting menu.



For basic functions, see [1 Basic Adjustment / Settings](#) [▶ 4].

2.1 Basic Operation of the Setting Menu

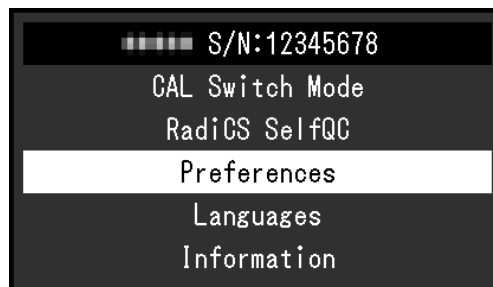
1. Touch any switch (except )
The operation guide appears.
2. Select 
The Setting menu appears.
3. Select a menu to adjust / set using  , then select .









The sub menu appears.

4. Select an item to adjust / set using  , then select .



The Adjustment / Setting menu appears.

5. Adjust / set the selected item using   or  , and then select .
Selecting  during adjustment/setting will cancel the adjustment/setting and restore the state prior to making changes.

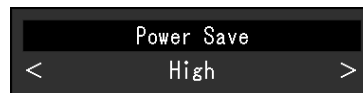

6. Selecting  several times will close the Setting menu.

2.2 Setting Menu Functions

2.2.1 CAL Switch Mode

The mode settings can be adjusted according to personal preference. The adjusted settings are saved for each mode.

- DICOM / CAL1 / CAL2

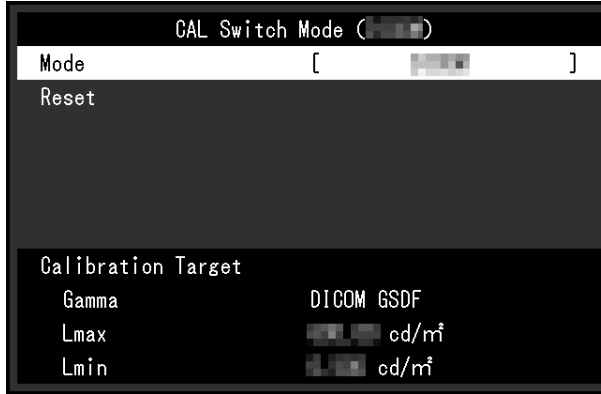

- Text



Functions that can be adjusted differ depending on the mode.

✓: Adjustable, -: Not adjustable

Function	CAL Switch Mode			
	1-DICOM	2-CAL1	3-CAL2	4-Text
Brightness	-	-	-	✓
Contrast	-	-	-	✓
Gamma	-	-	-	✓
Reset	✓	✓	✓	✓

Attention

- Please wait 15 minutes or more after the monitor power has been turned on or the monitor has recovered from the power saving mode before performing various tests for quality control, calibration, or screen adjustment of the monitor.

Note

- Use the value shown in "Brightness" as reference.

Mode

Settings: "1-DICOM" / "2-CAL1" / "3-CAL2" / "4-Text"

Switch to the mode that suits the usage of the monitor.

The mode settings can also be adjusted according to personal preference. Select the mode for adjustment and perform adjustment using the relevant functions.

Brightness

Settings: "0%" – "100%"

You can adjust the screen brightness by changing the brightness of the backlight (light source from the LCD back panel).

Note

- If the image is too bright even when the brightness is set to 0 %, adjust the contrast.

Contrast

Settings: "0%" – "100%"

You can adjust the brightness of the screen by varying the video signal level.

Note

- When the contrast is set to 100 %, all the monochrome gradations are shown.
- When adjusting the monitor, it is recommended to perform brightness adjustment, which does not lose gradation characteristics, prior to contrast adjustment.
- Perform contrast adjustment in the following cases.
 - If the screen is too bright even when the brightness is set to 0 %

Gamma

Settings: "1.6" – "2.7"

This function allows you to adjust the gamma. While the brightness of the monitor varies depending on the video level of the input signal, the variation rate is not directly proportional to the input signal. Maintaining the balance between the input signal and brightness of the monitor is referred to as "Gamma correction."

Reset

Resets adjustments made only for the currently selected mode back to the default settings.

2.2.2 RadiCS SelfQC

This product is equipped with an integrated Integrated Front Sensor (calibration sensor). With the Integrated Front Sensor, the monitor can independently perform quality control tasks, such as calibration and grayscale checks.

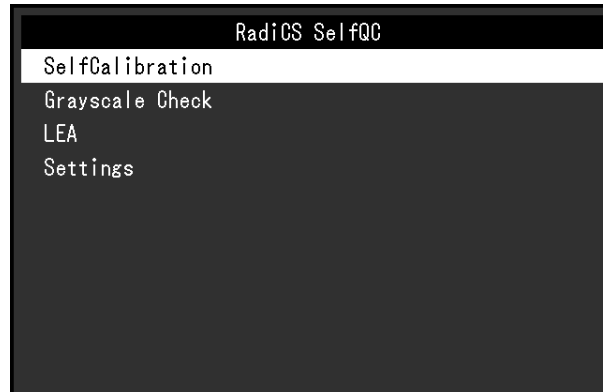

Note

- Calibration can be performed periodically by using the schedule function of RadiCS LE. For more information about the setup procedure, refer to the RadiCS LE Instructions for Use.
- RadiCS enables you to configure the schedule settings for Grayscale Check as well as for calibration. For more information about the setup procedure, refer to the RadiCS Instructions for Use.
- If you want to perform high-level quality control in compliance with medical standards and guidelines, use the optional monitor quality control software kit "RadiCS UX2."
- To match the measurement results of the integrated calibration sensor (Integrated Front Sensor) and the optional external sensor, perform correlation between the Integrated Front Sensor and the external sensor using RadiCS / RadiCS LE. Periodical correlation allows you to maintain the measurement result of the Integrated Front Sensor at a level equivalent to that of the external sensor. For details on correlation, refer to the RadiCS / RadiCS LE Instructions for Use.
- To ensure that the measurements from the built-in illuminance sensor are equivalent to those from an illuminance meter, use RadiCS / RadiCS LE to perform correlation of the illuminance sensor. For details on correlation of the illuminance sensor, refer to the RadiCS / RadiCS LE Instructions for Use.

SelfCalibration

Execute SelfCalibration and view the latest results.

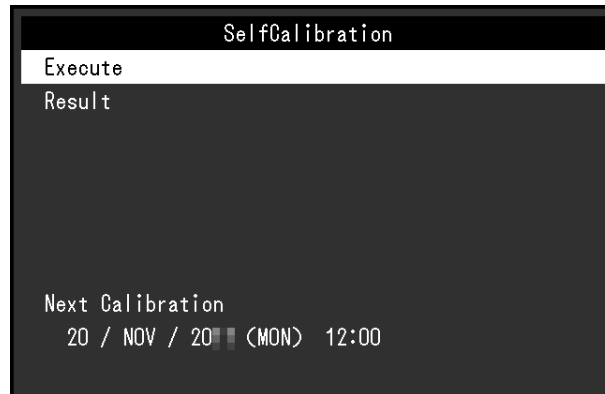

SelfCalibration - Execute

Executes SelfCalibration.

Attention

- If the power to the PC is turned off or the input signal switches while SelfCalibration is running, the execution will be canceled.
- After SelfCalibration is complete, perform Grayscale Check at the same room temperature and illuminance as those in the actual working environment.

Note

- The following items can be set by using RadiCS / RadiCS LE. For more information about the setup procedure, refer to RadiCS / RadiCS LE Instructions for Use.
 - Calibration target
 - SelfCalibration schedule
 - If you have configured the schedule using RadiCS / RadiCS LE, the next execution schedule is displayed.
- The calibration target value can be confirmed by selecting the target mode in "CAL Switch Mode" of the Setting menu.

SelfCalibration - Result

Settings: "DICOM" / "CAL1" / "CAL2"

The SelfCalibration execution results (such as Max. Error Rate, Last Time, and Error Code) for the selected mode are displayed.

Attention

- The results can be checked when "QC History" is set to "On" (see [Settings - Warning \[▶ 14\]](#), [Settings - QC History \[▶ 14\]](#)).

Grayscale Check

Perform Grayscale Check and view the latest results. Furthermore, if you have configured the schedule using RadiCS, the next execution schedule is displayed.

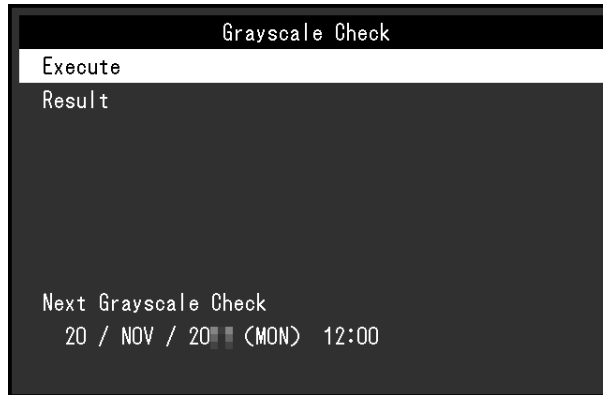

Grayscale Check - Execute

Executes Grayscale Check.

Attention
<ul style="list-style-type: none"> • Perform Grayscale Check based on the actual color temperature and brightness of the working environment.

Note
<ul style="list-style-type: none"> • The determination value for Grayscale Check can be specified from RadiCS. Refer to the RadiCS Instructions for Use for details. • The Grayscale Check schedule can be configured using RadiCS. For more information about the setup procedure, refer to the RadiCS Instructions for Use. If you have configured the schedule using RadiCS, the next execution schedule is displayed.

Grayscale Check - Result

Settings: "DICOM" / "CAL1" / "CAL2"

Up to five past execution results (Passed, Failed, Canceled, or Error) for the selected mode are displayed.

Attention
<ul style="list-style-type: none"> • The results can be checked when "QC History" is set to "On."

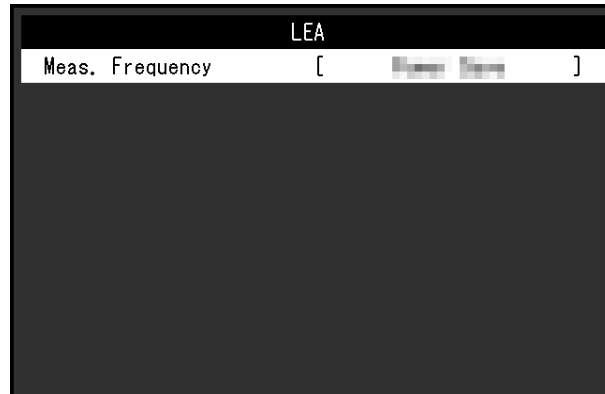
LEA**LEA - Meas. Frequency**

Settings: "Power Save" / "Routine" / "Off"

You can acquire data required to estimate the monitor's lifespan. The life estimation result based on the acquired data can be confirmed using RadiCS / RadiCS LE.

Note

- Data is collected every 100 hours.
- If you selected "Power Save" and 100 hours have elapsed, the data collection process runs when the monitor enters the power saving mode or the power is turned off.
- If "Routine" or "Power Save" is selected, the Integrated Front Sensor starts measurement at the time of data collection. If "Off" is selected, measurement using the Integrated Front Sensor is not performed at the time of data collection.
- The collected data is saved at the following timings:
 - 500, 1000, 2000, 4000, 7000, 10000, 15000, 20000, 25000, 30000, 35000, 40000, 45000, and 50000 hours

Settings



Settings - Warning

Settings: "On" / "Off"

If this function is set to "On," a warning is displayed if the result of Grayscale Check is "Failed."

Settings - QC History

Settings: "On" / "Off"

If this function is set to "On," the execution results (QC history) of SelfCalibration and Grayscale Check are displayed.

2.2.3 Preferences

The monitor settings can be configured to suit the usage environment or your preference.



Input

Settings: "DisplayPort 1" / "DisplayPort 2" / "DVI"

You can select the input signal to be displayed on the screen (see [1.2 Switching Input Signals](#) [▶ 5]).

Auto Input Detection

Settings: "On" / "Off"

This product automatically detects the connector through which a signal is input, and displays the signal on the screen.

- On
Automatically detects the connector through which a signal is input, and displays the signal on the screen.
If the PC that is outputting the signal displayed on the screen enters the power saving mode or is turned off when multiple PCs are connected, any other available signal is displayed automatically.
- Off
When selecting the input signal manually, select this setting. When you want to switch the input signal, see [1.2 Switching Input Signals](#) [▶ 5].

Note

- If you turn the main power off and on again, the input signal is automatically detected regardless of the setting.

Power Save

Settings: "High" / "Low" / "Off"

You can specify whether the monitor enters the power saving mode according to the PC status.

- High
Turns the backlight off. This provides the highest power saving effect.
- Low
Sets the backlight to the lowest lighting level. The time until operation stabilizes after restoring from power saving mode can be reduced.
- Off
Does not enable the power saving mode. The backlight lights up irrespective of the PC status. This setting may shorten the backlight life.

Note

- When not using the monitor, you can turn off the main power supply or disconnect the power plug so that the power is cut completely.
- Devices connected to the USB upstream port and downstream port still work when the monitor is in the power saving mode or when the power is switched off using the power button (⏻) of the monitor. For this reason, power consumption of the monitor varies with connected devices even in the power saving mode.
- When the signal input from the PC is no longer detected, a message appears notifying the user of the transition to power saving mode. The monitor enters power saving mode five seconds after the message appears.
- When power save is set to "High" or "Low", the status of the monitor can be confirmed by checking the color of the indicator on the power switch.
 - Power indicator is green: Monitor is in normal operation mode
 - Power indicator is orange: Monitor is in power saving mode

Indicator

Settings: "1" – "7" / "Off"

The brightness of the power switch indicator (green) while the screen is displayed can be adjusted. The larger the set value, the brighter the power indicator lights up. On the other hand, the smaller the value, the darker it becomes. The "Off" setting turns off the power switch indicator.

USB Selection

Settings: "On" / "Off"

You can specify whether to display the icon for switching the USB ports (🔌) in the operation guide.

If "On" is selected, the icon for switching the USB ports is shown in the operation guide.

Attention

- If "Off" is specified, the PC currently connected to "USB 1" is enabled even when "USB 2" is selected.

Mode Skip

This function allows you to skip certain display modes when selecting a mode.

Please use this function if you want to limit the modes to be displayed, or avoid changing the display status randomly.

Attention

- Not all modes can be disabled (skipped). Set at least one mode to "-".

Monitor Reset

Restores all settings to their default settings except for the following settings:

- Settings on the "Administrator Settings" menu

Attention

- The previous settings cannot be recovered after they are reset to the default settings.

Note

- For details on default settings, see [5.3 Main Default Settings \[▶ 28\]](#).

2.2.4 Languages

Settings: "English" / "German" / "French" / "Spanish" / "Italian" / "Swedish" / "Japanese" / "Simplified Chinese" / "Traditional Chinese"

The display language for menus and messages can be selected.

**2.2.5 Information**

You can check the monitor information (model name, serial number (S/N), firmware version, usage time) and the input signal information.

The asset tag number is only displayed when it has been set using RadiCS / RadiCS LE.

Example:

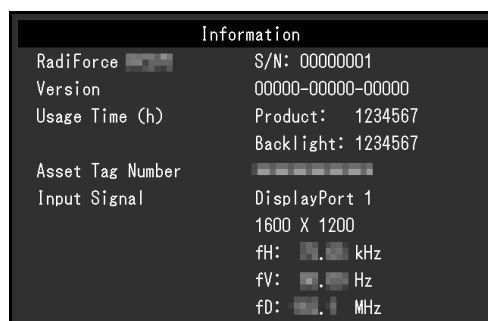





**Attention**

- The usage time may not be "0" at the time of your purchase because inspections and other processes had been carried out on the monitor before it was shipped from the factory.

3 Administrator Settings

This chapter describes how to configure monitor operation using the "Administrator Settings" menu.

3.1 Basic Operations of the "Administrator Settings" Menu

1. Touch  to turn off the monitor.
2. While touching the leftmost switch , touch  for more than 2 seconds to turn on the monitor.
The "Administrator Settings" menu appears.
3. Select an item to set with   and select .



The Adjustment / Setting menu appears.

4. Perform adjustment/setting with   or   and select .



5. In the "Administrator Settings" menu, select "Apply", and then select .
The settings are applied and the "Administrator Settings" menu exits.

3.2 Functions of the "Administrator Settings" Menu

Key Lock

Settings: "Off" / "Menu" / "All"

In order to prevent changes to settings, the operation switches on the front of the monitor can be locked.

- "Off"
Enables all switches.
- "Menu"
Locks the  switch.
- "All"
Locks all switches except the power switch.

Note

- After calibration is performed using RadiCS / RadiCS LE, "Key Lock" - "Menu" is selected.

Image Rotation

Settings: "Portrait" / "Landscape"

This function allows you to change the image display orientation according to the monitor installation orientation.

DP Power Save

Settings: "On" / "Off"

Connecting a PC to the DisplayPort connector enables DisplayPort™ communication, and thus consumes high power even in the power saving mode. The communication can be disabled by setting "DP Power Save" to "On". This reduces power consumption in the power saving mode.

Attention

- If "On" is selected, window and icon positions may shift when the monitor is powered on/off or returned from the power saving mode. In such cases, set this function to "Off".

Grayscale Warning

Settings: "On" / "Off"

You can specify whether to display the Grayscale Display Error message to indicate that a 6-bit (64-grayscale) signal has been detected when the DisplayPort signal is input at the recommended resolution. If the error message appears, please turn off the main power, and then turn it on again.

Attention

- Always use with this set to "On" (the default setting is "On").
- Set this to "Off" only when using 6-bit (64 grayscale) display.

Sharpness Recovery

Settings: "On" / "Off"

EIZO's unique technology called "Sharpness Recovery" improves picture clarity and displays images that are true to the original source data.

Attention

- After changing the setting, perform a visual check according to the medical standards / guidelines.

Signal Format - DisplayPort 1 / DisplayPort 2 / DVI - Sub Pixel Drive (Hor.)

Settings: "On" / "Off"

By enabling Sub Pixel Drive, you can display with a high resolution of 15 mega subpixels (6144 x 2560).

Attention

- If "Sub Pixel Drive (Hor.)" is set to "On," the screen is not displayed properly. Leave the setting "Off" as it is.
- When displaying at 15 mega subpixels (15 MsP), software compatible with 15 MsP display is required.
- When placed vertically, the subpixels are arranged horizontally.
- If "On" is set, "Sharpness Recovery" will be disabled regardless of its setting.

Signal Format - DisplayPort 1 - Version

Settings: "1.1" / "1.2"

The version for DisplayPort 1 () can be set.

Attention

- To use a daisy-chain connection, set the version to "1.2."
- When a PC is connected via the DisplayPort connector, the DisplayPort version may differ depending on the PC, and consequently the screen may not appear. In this case, try changing the following settings.
- The DisplayPort 2 () version is fixed at "1.1."

Signal Format - DVI - Preferred Refresh Rate

Settings: "High" / "Low"

Set the DVI refresh rate (screen update frequency) to suit your environment.

4 Troubleshooting

4.1 No Picture





Power switch indicator does not light up

- Check whether the power cord is connected properly.
- Turn on the main power switch on the left side.
- Touch .
- Turn off the main power switch on the left side, and then turn it on again a few minutes later.

Power switch indicator lights up: Green

- Increase the adjustment values for "Brightness" and "Contrast" (only for "4-Text" mode) in the Setting menu (see [CAL Switch Mode](#)  8]).
- Turn off the main power switch on the left side, and then turn it on again a few minutes later.

Power switch indicator lights up: Orange

- Try switching the input signal (see [1.2 Switching Input Signals](#)  5]).
- Move the mouse or press any key on the keyboard.
- Check whether the PC is turned on.
- Check whether the signal cable is connected properly. Connect to  when "DisplayPort 1" is selected, and to  when "DisplayPort 2" is selected in the input signal.  is used for output when a daisy-chain connection is set up.
- Turn off the main power switch on the left side of the monitor, and then turn it on again.



Power switch indicator blinks: Orange, Green



- Connect via the signal cable specified by EIZO. Turn off the main power switch on the left side of the monitor, and then turn it on again a few minutes later.
- If the signal cable is connected to DisplayPort 1 () , try switching the DisplayPort version (see [Signal Format - DisplayPort 1 - Version](#)  20]).

The message "No Signal" appears on the screen

Example:



- The message shown above may appear as some PCs do not output the signal immediately after power-on.
- Check whether the PC is turned on.
- Check whether the signal cable is connected properly. Connect the signal cables to the connectors of the corresponding input signal.
- Try switching the input signal (see [1.2 Switching Input Signals](#)  5]).
- If the signal cable is connected to DisplayPort 1 () , try switching the DisplayPort version (see [Signal Format - DisplayPort 1 - Version](#)  20]).

- Check whether the signal cable is connected properly. Is the signal cable connected to  or  for inputting the DisplayPort signal?  is used for output when a daisy-chain connection is set up.
- Turn off the main power switch on the left side of the monitor, and then turn it on again.

The message "Signal Error" appears on the screen

Example:

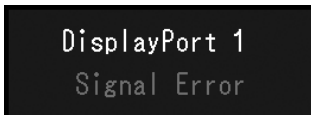

- Check whether the PC is configured to meet the resolution and vertical scan frequency requirements of the monitor (see "Compatible Resolutions" in the Instructions for Use).
- Reboot the PC.
- Select an appropriate setting using the graphics board's utility. Refer to the User's Manual of the graphics board for details.

4.2 Imaging Problems

The screen is too bright or too dark

- Adjust "Brightness" or "Contrast" in the Setting menu to adjust it (see [CAL Switch Mode \[▶ 8\]](#)). The LCD monitor backlight has a limited life span. When the screen becomes dark or begins to flicker, contact your local EIZO representative.

Text is blurred

- Check whether the PC is configured to meet the resolution and vertical scan frequency requirements of the monitor (see "Compatible Resolutions" in the Instructions for Use).
- Try setting the magnification of display on the OS to "100 %". When using multiple monitors, try setting the magnification of display to "100 %" on all monitors.

An afterimage can be seen

- Afterimages are particular to LCD monitors. Avoid displaying the same image for a long time.
- Use the screen saver or power save function if you are going to be displaying the same image for extended periods of time.
- An afterimage may appear even after a short time period has elapsed depending on the displayed image. To remove such a phenomenon, change the image or keep the power turned off for several hours.

White dots or unlit dots remain on the screen

- This is common with LCD panels, and is not a malfunction.

Interference patterns or pressure marks remain on the LCD panel

- Leave the monitor with a white or black screen. The symptom may disappear.

4.3 Other Problems

The Setting menu does not appear

- Check whether the operation switch lock function is active (see [Key Lock \[▶ 18\]](#)).

The Mode menu does not appear

- Check whether the operation switch lock function is active (see [Key Lock \[▶ 18\]](#)).

The operation switches do not work

- Check whether the operation switch lock function is active (see [Key Lock \[▶ 18\]](#)).
- Check whether there are any water droplets or foreign objects on the switch surface. Gently wipe the switch surface and try operating the switches again with dry hands.
- Are you wearing gloves? If so, remove the gloves and try operating the switches again with dry hands.

USB peripheral devices connected to the monitor do not work

- Check whether the USB cable is correctly connected between the PC and the USB upstream port on the monitor (see [5.2 Using the USB Hub Function \[▶ 27\]](#)).
- Check whether the peripheral device is correctly connected to the USB downstream port on the monitor (see [5.2 Using the USB Hub Function \[▶ 27\]](#)).
- Try using a different USB downstream port on the monitor.
- The USB Type-C® (hereinafter USB-C®) connector is for charging only. Peripheral devices will not operate.
- Try using a different USB port on the PC.
- Check whether the device drivers of the peripheral devices are up-to-date.
- Reboot the PC.
- If the peripheral devices work correctly when they are directly connected to the PC, contact your local EIZO representative.
- Check the PC's BIOS (UEFI) setting for USB when using Windows. (See the manual of the PC for details.)
- Check if the operating system of the PC is up-to-date.
- If you are using macOS Ventura (13) or later, select "Allow" in the "Allow accessory to connect?" message window that appears when connecting via USB.

The Integrated Front Sensor stays out

- Turn off the main power, and then turn it on again.

RadiCS fails to connect to the monitor

- Check that the USB cable is not pulled out.
- Connect to  when performing quality control with RadiCS. When "USB Selection" is "On", select "USB 1".

SelfCalibration / Grayscale Check fails

- Refer to [4.4 Error Code Table \[▶ 24\]](#).
- If an error code that does not appear in the error code table is displayed, contact your dealer or local EIZO representative.

Attention

- Do not touch the Integrated Front Sensor.

The SelfCalibration / Grayscale Check history does not display the clock time correctly

- Perform monitor detection using RadiCS / RadiCS LE. For details, refer to the RadiCS / RadiCS LE Instructions for Use.

4.4 Error Code Table

Error Code	Description
****50	<ul style="list-style-type: none"> • The maximum brightness of the monitor may be lower than the target brightness. • Try reducing the target brightness.
****52	<ul style="list-style-type: none"> • The minimum brightness of the monitor may be higher than the target minimum brightness. • Try increasing the target minimum brightness.
****05	<ul style="list-style-type: none"> • The sensor may not have worked correctly. • Turn off the main power, wait for a few minutes, turn the power back on, and then run SelfCalibration / Grayscale Check again.
****20 ****21	<ul style="list-style-type: none"> • The sensor may not have worked correctly. • Check whether there is any foreign object near the sensor. • Run SelfCalibration / Grayscale Check again.

5 Reference

5.1 Arm Installation Procedure

A monitor arm (or a stand) by another manufacturer can be attached by removing the stand section.

When attaching a monitor arm or stand, the installable orientations and movement range (tilt angle) are as follows:

- Orientation

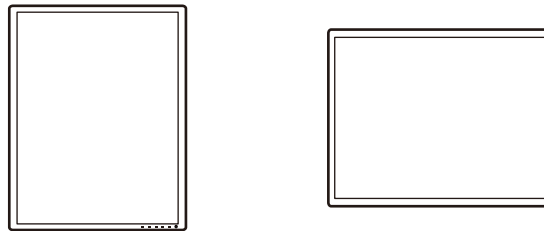

- Movement range (tilt angle)

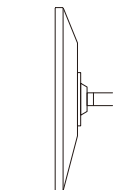

Standard



Up: 30°

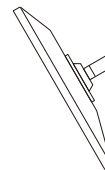

Down: 30°

Attention

- When attaching a monitor arm or stand, follow the instructions of the respective User's Manual.
- When using a monitor arm or stand of another manufacturer, confirm the following in advance and select one conforming to the VESA standard:
 - Clearance between the screw holes: 100 mm x 100 mm
 - Arm or stand VESA mount dimensions: 122.6 mm x 122.6 mm or less
 - Strong enough to support weight of the monitor unit (excluding the stand) and attachments such as cables
- When using another manufacturer's arm or stand, use the following screws to secure it.
 - Screws fixing the stand to the monitor
- Connect the cables after attaching an arm or stand.
- Do not move the removed stand up and down. Doing so may result in injury or device damage.
- The monitor, arm, and stand are heavy. Dropping them may result in injury or equipment damage.
- Check periodically that the screws are tight enough. If not sufficiently tight, the monitor may detach from the arm, which may result in injury or equipment damage.

1. In order to prevent the LCD panel surface from being scratched, lay the monitor on a soft cloth spread on a stable surface with the LCD panel surface facing down.
2. Prepare a screwdriver. Using a screwdriver, remove the screws (four) securing the unit and the stand.
3. Use the screws that you removed in step 2 to attach the arm (or stand) to the monitor.

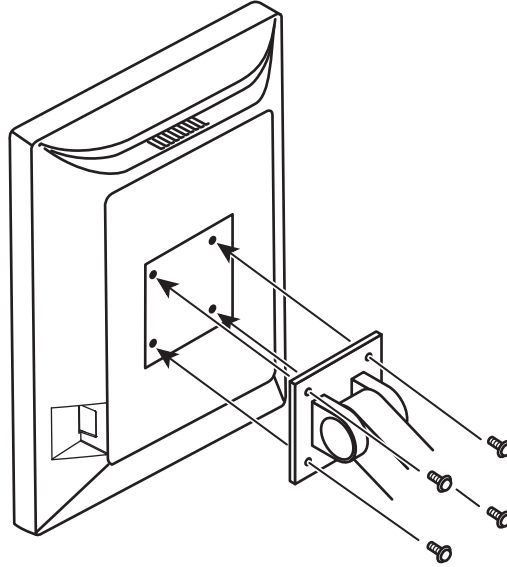

5.2 Using the USB Hub Function

This monitor is equipped with a USB hub. Connected to a PC compatible with USB or another monitor with a USB hub, this monitor functions as a USB hub allowing connection to peripheral USB devices.

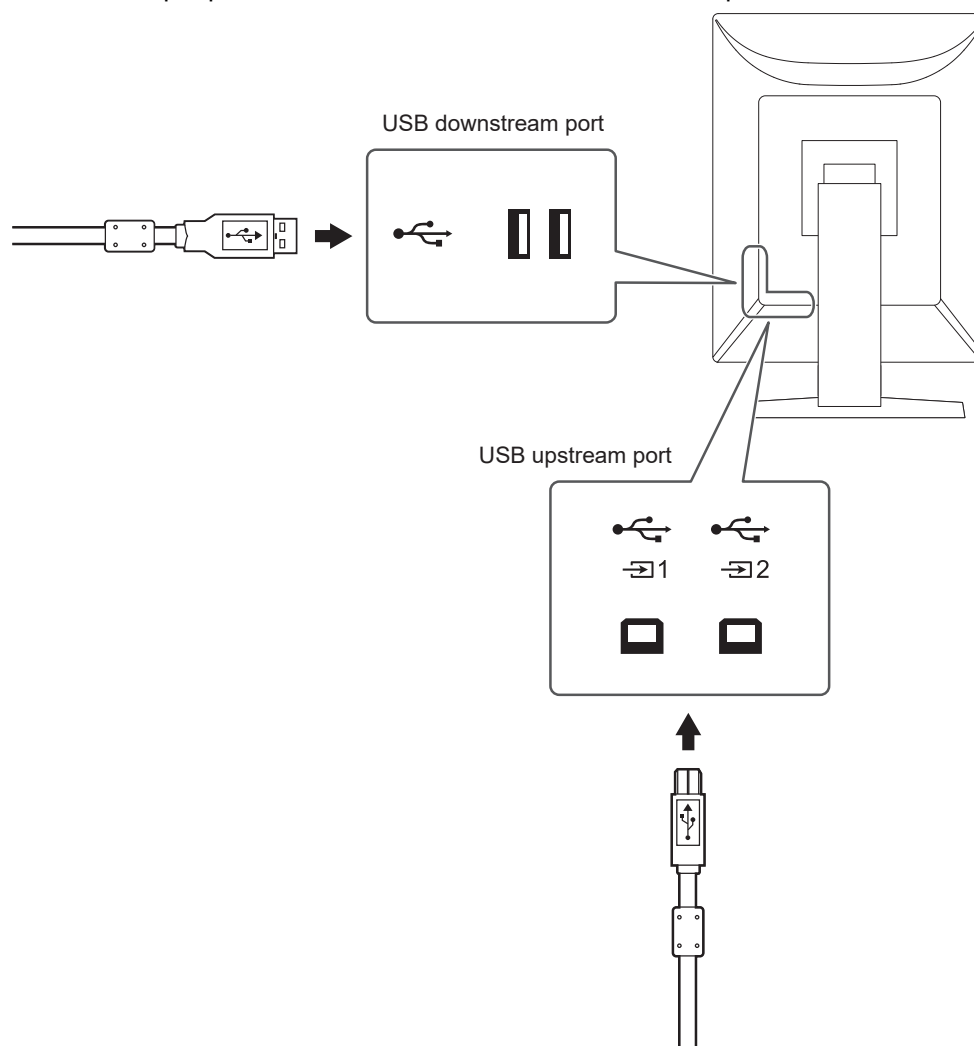

1. Connect the supplied USB cable between the USB downstream port of a PC (or another monitor that has a USB hub) and the monitor's USB upstream port.
2. Connect the peripheral USB device to the USB downstream port of the monitor.



Attention

- When the main power switch is turned off, a device connected to the USB downstream port will not work.
- Connect a PC with RadiCS / RadiCS LE installed to  1 to perform monitor quality control.
- The USB-C connector is for charging only, so it cannot be used as a USB hub.

Note

- A cap is attached to  2 by default. Remove the cap when using .
- By default,  1 is enabled. If you want to connect two PCs and switch them to operate USB devices, see [1.4 Switching PCs Used to Operate USB Devices](#) [▶ 6].

5.3 Main Default Settings

5.3.1 CAL Switch Mode

Factory default display setting is "1-DICOM."

Mode	Brightness	Gamma
1-DICOM	600 cd/m ²	DICOM GSDF
2-CAL1	500 cd/m ²	DICOM GSDF
3-CAL2	1000 cd/m ²	DICOM GSDF
4-Text	Approx. 100 cd/m ²	2.2

5.3.2 Others

LEA - Meas. Frequency	Power Save
Settings - Warning	Off
Settings - QC History	On
Input	DisplayPort 1 ^{*1}
Auto Input Detection	Off
Power Save	High
Indicator	4
USB Selection	Off
Mode Skip	- (Display all)
Languages	English
Key Lock	Off ^{*1}
Image Rotation	Portrait ^{*1}
DP Power Save	Off ^{*1}
Grayscale Warning	On ^{*1}
Sharpness Recovery	On ^{*1}
Signal Format - DisplayPort 1 - Sub Pixel Drive (Hor.)	Off ^{*1}
Signal Format - DisplayPort 1 - Version	1.1 ^{*1}
Signal Format - DisplayPort 2 - Sub Pixel Drive (Hor.)	Off ^{*1}
Signal Format - DVI - Sub Pixel Drive (Hor.)	Off ^{*1}
Signal Format - DVI - Preferred Refresh Rate	Low ^{*1}
USB Selection ()	USB 1

*1 These menus cannot be initialized by executing "Monitor Reset" (see [Monitor Reset \[▶ 16\]](#)).

Appendix

Trademark

The terms HDMI, HDMI High-Definition Multimedia Interface, HDMI trade dress and the HDMI Logos are trademarks or registered trademarks of HDMI Licensing Administrator, Inc. DisplayPort and the DisplayPort Compliance Logo are trademarks of the Video Electronics Standards Association in the United States and other countries.

The SuperSpeed USB Trident Logo is a registered trademark of USB Implementers Forum, Inc.



The SuperSpeed USB Power Delivery Trident Logos are trademarks of USB Implementers Forum, Inc.



USB Type-C and USB-C are registered trademarks of USB Implementers Forum, Inc.

DICOM is the registered trademark of the National Electrical Manufacturers Association for its standards publications relating to digital communications of medical information.

Kensington and Microsaver are registered trademarks of ACCO Brands Corporation.

Thunderbolt is a trademark of Intel Corporation in the United States and/or other countries.

Microsoft and Windows are registered trademarks of Microsoft Corporation in the United States and other countries.

Adobe is a registered trademark of Adobe Inc. in the United States and other countries.

Apple, macOS, Mac OS, OS X, macOS Sierra, Macintosh and ColorSync are trademarks of Apple Inc.

ENERGY STAR is a registered trademark of the United States Environmental Protection Agency in the United States and other countries.

EIZO, the EIZO Logo, ColorEdge, CuratOR, DuraVision, FlexScan, FORIS, RadiCS, RadiForce, RadiNET, Raptor, and ScreenManager are registered trademarks of EIZO Corporation in Japan and other countries.

RadiLight and ScreenCleaner are trademarks of EIZO Corporation.

All other company names, product names, and logos are trademarks or registered trademarks of their respective owners.

License

The bitmap font used for this product is designed by Ricoh Industrial Solutions Inc.

License information for the open source software used in this product is available at www.eizoglobal.com/support/oss/.

LIMITED WARRANTY

EIZO Corporation (hereinafter referred to as “EIZO”) and distributors authorized by EIZO (hereinafter referred to as the “Distributors”) warrant, subject to and in accordance with the terms of this limited warranty (hereinafter referred to as the “Warranty”), to the original purchaser (hereinafter referred to as the “Original Purchaser”) who purchased the product specified in this document (hereinafter referred to as the “Product”) from EIZO or Distributors, that EIZO and Distributors shall, at their sole discretion, either repair or replace the Product at no charge if the Original Purchaser becomes aware within the Warranty Period (defined below) that (i) the Product malfunctions or is damaged in the course of normal use of the Product in accordance with the description in the instruction manual of the Product (hereinafter referred to as the “User’s Manual”), or (ii) the LCD panel and brightness of the Product cannot maintain the recommended brightness specified in the User’s Manual in the course of normal use of the Product in accordance with the description of the User’s Manual.

The period of this Warranty is five (5) years from the date of purchase of the Product (hereinafter referred to as the “Warranty Period”).

However, the brightness of the Product shall be warranted only if the Product has been used within the recommended brightness described in the User’s Manual.

The Warranty Period for the brightness is also limited to five (5) years from the date of purchase of the Product (the brightness is 1000 cd/m²) subject to the usage time being less than or equal to 43,800 hours.

EIZO and Distributors shall bear no liability or obligation with regard to the Product in relation to the Original Purchaser or any third parties other than as provided under this Warranty.

EIZO and Distributors will cease to hold or store any parts (excluding design parts) of the Product upon expiration of seven (7) years after the production of the Product is discontinued.

In repairing the Product, EIZO and Distributors will use renewal parts which comply with our QC standards. If the unit cannot be repaired due to its condition or the stockout of a relevant part, EIZO and Distributors may offer the replacement by a product with equivalent performance instead of repairing it.

The Warranty is valid only in the countries or territories where the Distributors are located. The Warranty does not restrict any legal rights of the Original Purchaser.

Notwithstanding any other provision of this Warranty, EIZO and Distributors shall have no obligation under this Warranty whatsoever in any of the cases as set forth below:

1. Any defect of the Product caused by freight damage, modification, alteration, abuse, misuse, accident, incorrect installation, disaster, adherent dust, faulty maintenance and/or improper repair by third party other than EIZO and Distributors;
2. Any incompatibility of the Product due to possible technical innovations and/or regulations;
3. Any deterioration of the sensor, including measurement value of the sensor;
4. Any defect of the Product caused by external equipments;
5. Any defect of the Product caused by the use under environmental conditions not anticipated by EIZO;
6. Any deterioration of the attachments of the Product (e.g. cables, User’s Manual, CD-ROM, etc.);
7. Any deterioration of the consumables, and/or accessories of the Product (e.g. batteries, remote controller, touch pen, etc.);
8. Any exterior deterioration or discoloration of the Product, including that of the surface of the LCD panel, the touch panel and the protect panel;

9. Any defect of the Product caused by placement in a location where it may be affected by strong vibrations or shocks;
10. Any defect of the Product caused by leaking battery liquid;
11. Any deterioration of the Product caused by the use at higher brightness than the recommended brightness described in the User's Manual;
12. Any deterioration of display performance caused by the deterioration of expendable parts such as the LCD panel and/or backlight, etc. (e.g. changes in brightness uniformity, changes in color, changes in color uniformity, defects in pixels including burnt pixels, etc.);
13. Any deterioration or malfunction of the cooling fan caused by adherent dust.

To obtain service under the Warranty, the Original Purchaser must deliver the Product, freight prepaid, in its original package or other adequate package affording an equal degree of protection, assuming the risk of damage and/or loss in transit, to the local Distributor. The Original Purchaser must present proof of purchase of the Product and the date of such purchase when requesting services under the Warranty.

The Warranty Period for any replaced and/or repaired product under this Warranty shall expire at the end of the original Warranty Period.

EIZO OR DISTRIBUTORS ARE NOT RESPONSIBLE FOR ANY DAMAGE TO, OR LOSS OF, DATA OR OTHER INFORMATION STORED IN ANY MEDIA OR ANY PART OF ANY PRODUCT RETURNED TO EIZO OR DISTRIBUTORS FOR REPAIR.

EIZO AND DISTRIBUTORS MAKE NO FURTHER WARRANTIES, EXPRESSED OR IMPLIED, WITH RESPECT TO, INCLUDING, WITHOUT LIMITATION, THE PRODUCT AND ITS QUALITY, PERFORMANCE, MERCHANTABILITY OR FITNESS FOR ANY PARTICULAR USE.

IN NO EVENT SHALL EIZO OR DISTRIBUTORS BE LIABLE FOR ANY INCIDENTAL, INDIRECT, SPECIAL, CONSEQUENTIAL OR OTHER DAMAGE WHATSOEVER (INCLUDING, WITHOUT LIMITATION, DAMAGES FOR LOSS OF PROFIT, BUSINESS INTERRUPTION, LOSS OF BUSINESS INFORMATION, OR ANY OTHER PECUNIARY LOSS) ARISING OUT OF THE USE OR INABILITY TO USE THE PRODUCT OR IN ANY CONNECTION WITH THE PRODUCT, WHETHER BASED ON CONTRACT, TORT, NEGLIGENCE, STRICT LIABILITY OR OTHERWISE, EVEN IF EIZO OR DISTRIBUTORS HAVE BEEN ADVISED OF THE POSSIBILITY OF SUCH DAMAGES.

THIS EXCLUSION ALSO INCLUDES ANY LIABILITY WHICH MAY ARISE OUT OF THIRD PARTY CLAIMS AGAINST THE ORIGINAL PURCHASER. THE ESSENCE OF THIS PROVISION IS TO LIMIT THE POTENTIAL LIABILITY OF EIZO AND DISTRIBUTORS ARISING OUT OF THIS LIMITED WARRANTY AND/OR SALES.

