



User's Manual

DuraVision® MDU5501WT

Touch Panel Color LCD Monitor

Important

Please read this "User's Manual", and "Setup Manual" (separate volume) carefully to familiarize yourself with safe and effective usage.

-
- Refer to the "Setup Manual" for information on the installation / connection of the monitor.
 - For the latest product information including the "User's Manual", refer to our web site :
www.eizoglobal.com
-

No part of this manual may be reproduced, stored in a retrieval system, or transmitted, in any form or by any means, electronic, mechanical, or otherwise, without the prior written permission of EIZO Corporation. EIZO Corporation is under no obligation to hold any submitted material or information confidential unless prior arrangements are made pursuant to EIZO Corporation's receipt of said information. Although every effort has been made to ensure that this manual provides up-to-date information, please note that EIZO monitor specifications are subject to change without notice.

Notice for this monitor

About the Usage of This Product

This product may not be covered by warranty for uses other than those described in the Setup Manual.

The specifications noted in this manual are only applicable when using power cords and signal cables specified by us.

Only use optional products manufactured or specified by us with this product.

About the LCD Panel

It takes about 30 minutes (under our measurement conditions) for the monitor display to stabilize. Please wait 30 minutes or more after the monitor power has been turned on, and then adjust the monitor.

Extended use of a monitor causes the screen parts to degrade. To reduce that and prolong the life of your monitor, we recommend using it with a lower Brilliance setting.

When the screen image is changed after displaying the same image for extended periods of time, an afterimage may appear. Use the screen saver or power save function to avoid displaying the same image for extended periods of time. Depending on the image, an afterimage may appear even if it was displayed for a short period of time. To remove such a phenomenon, change the image or keep the power turned off for several hours.

If the monitor displays continuously over a long period of time, dark smudges or burn-in may appear. To maximize the life of the monitor, we recommend the monitor be turned off periodically.

The LCD panel is manufactured using high-precision technology. Although, missing pixels or lit pixels may appear on the LCD panel, this is not a malfunction. Percentage of effective dots: 99.9994 % or higher.

Do not splash detergent or hot water on the surface of the LCD panel, or bring any open flames close to it. Doing so may cause the coating on the monitor surface to peel off and leave distinguishing traces.

The backlight of the LCD panel has a fixed lifetime. Depending on the usage pattern, such as usage for long continuous periods, the lifespan of the backlight may run out sooner, requiring replacement. When the screen becomes dark or begins to flicker, please contact your local EIZO representative.

Do not scratch or press on the LCD panel with any sharp objects, at this may result in damage to the LCD panel. Do not attempt to brush with tissues as this may scratch the panel.

(Cautions for the Use of the Touch Panel)

During touch operation

Be careful of the following points. Otherwise, damage may occur to the monitor.

- Do not place any objects on the touch panel.
 - Do not strongly press, scratch, or poke the panel.
 - Do not touch the panel with hard objects such as ballpoint pens or metals.
-

About the Installation

When the monitor is cold and brought into a room or the room temperature goes up quickly, dew condensation may occur on the interior and exterior surfaces of the monitor. In that case, do not turn the monitor on. Instead wait until the dew condensation disappears, otherwise it may cause some damage to the monitor.

Dew may form on the back of the touch panel but this does not indicate a defect. The dew will disappear after a while.

About the Maintenance

Periodic cleaning is recommended to keep the monitor looking new and to prolong its operation lifetime (refer to [“Cleaning” \(page 4\)](#)).

Cleaning

The stains on the cabinet and LCD panel surface can be removed by using the provided cleaning cloth.

Attention

- If water or other kinds of liquid are on the surface of the LCD panel, promptly wipe it off as it may disrupt touch operations.
 - Chemicals such as alcohol and antiseptic solution may cause gloss variation, tarnishing, and fading of the cabinet or LCD panel, and also quality deterioration of the image.
 - Never use thinner, benzine, wax, or abrasive cleaner as they may damage the cabinet or LCD panel surface.
-

To use the monitor comfortably

- An excessively dark or bright screen may affect your eyes. Adjust the brightness of the monitor according to the environmental conditions.
- Staring at the monitor for a long time tires your eyes. Take a 10-minute rest every hour.

CONTENTS

Notice for this monitor	3	Appendix	32
Cleaning	4	Trademark	32
To use the monitor comfortably	4	License	32
CONTENTS	5	Testing Standard	32
Chapter 1 Introduction	6	Type Approval of Ship Classification	33
1-1. Features	6	Other Certifications	33
1-2. Controls and Functions	7	Warning for Radio interference	33
● Front / Back	7	LIMITED WARRANTY	34
● Side face	8	Recycling Information	35
Chapter 2 Adjusting Screens	10	Removing the stylus battery (disposal)	39
2-1. Adjusting the Brightness	10		
2-2. Switching Input Signals	10		
2-3. Configuring Advanced Adjustments / Settings	11		
● Basic adjustment menu operations	11		
● Color	12		
● Signal	14		
● Preferences	16		
● Languages	17		
● Information	17		
Chapter 3 Administrator Settings	18		
3-1. Basic Operation of the "Administrator Settings" Menu	18		
3-2. "Administrator Settings" Menu Functions ...	19		
Chapter 4 Troubleshooting	21		
4-1. No Picture	21		
4-2. Imaging Problems	22		
4-3. Touch Panel Problems	23		
4-4. Other Problems	25		
Chapter 5 Maintenance	26		
5-1. How to replace the cooling fan	26		
5-2. Periodic check of buzzer alarm	28		
Chapter 6 Reference	29		
6-1. Specifications	29		
● Main default settings	30		
6-2. Supported Resolutions	31		

Chapter 1 Introduction

Thank you very much for choosing an EIZO color LCD monitor with the touch panel.

1-1. Features

- The 55" LCD enables you to view electronic marine charts as if they were paper marine charts spread out in front of you.
- Resolution: Supports 4K (3840 × 2160)
- It can be used in table format.
- Equipped with a touch panel. You can operate the screen by touching it.
 - Includes a "Palm Rejection Function" that prevents misinputs caused by contact size that are larger than the size of a finger, such as your palm.
 - Includes a "Water Detection Function" that disables touch operation when water and foreign objects are detected.
- Includes PbyP (Picture by Picture) and PinP (Picture in Picture) functions. Multiple images can be displayed at the same time.

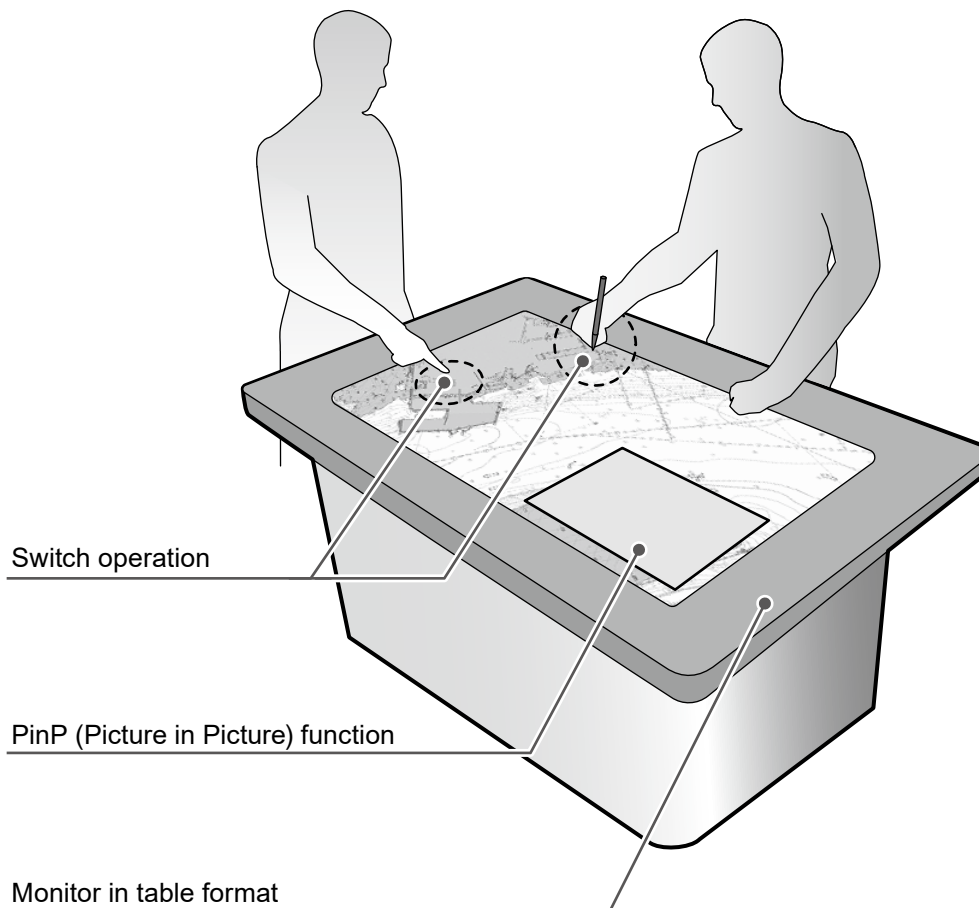

Attention

- When using the monitor in table format, do not place water or objects on top of the monitor. This may cause malfunction.

1-2. Controls and Functions



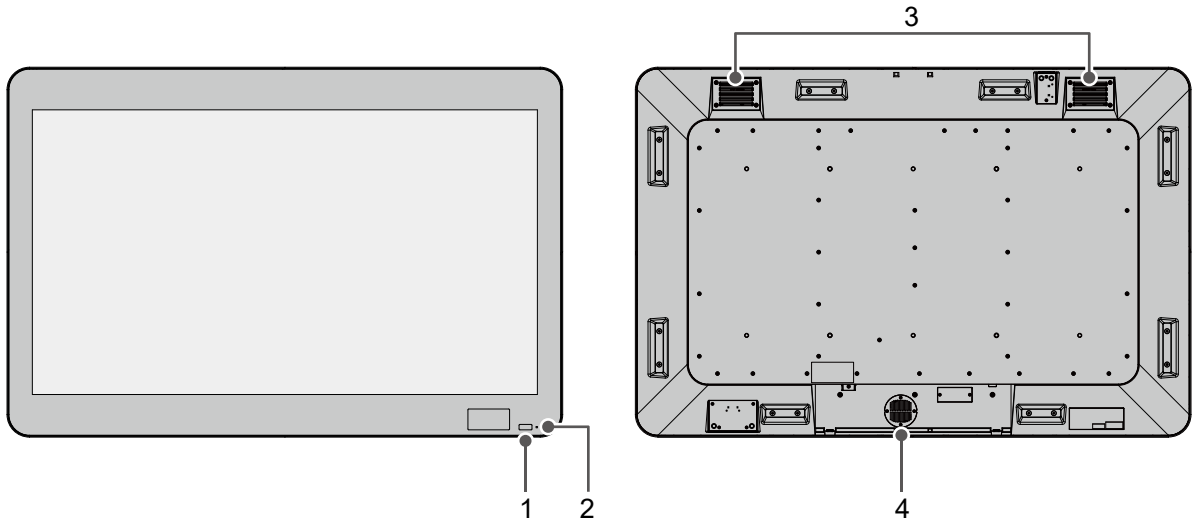



● Front / Back

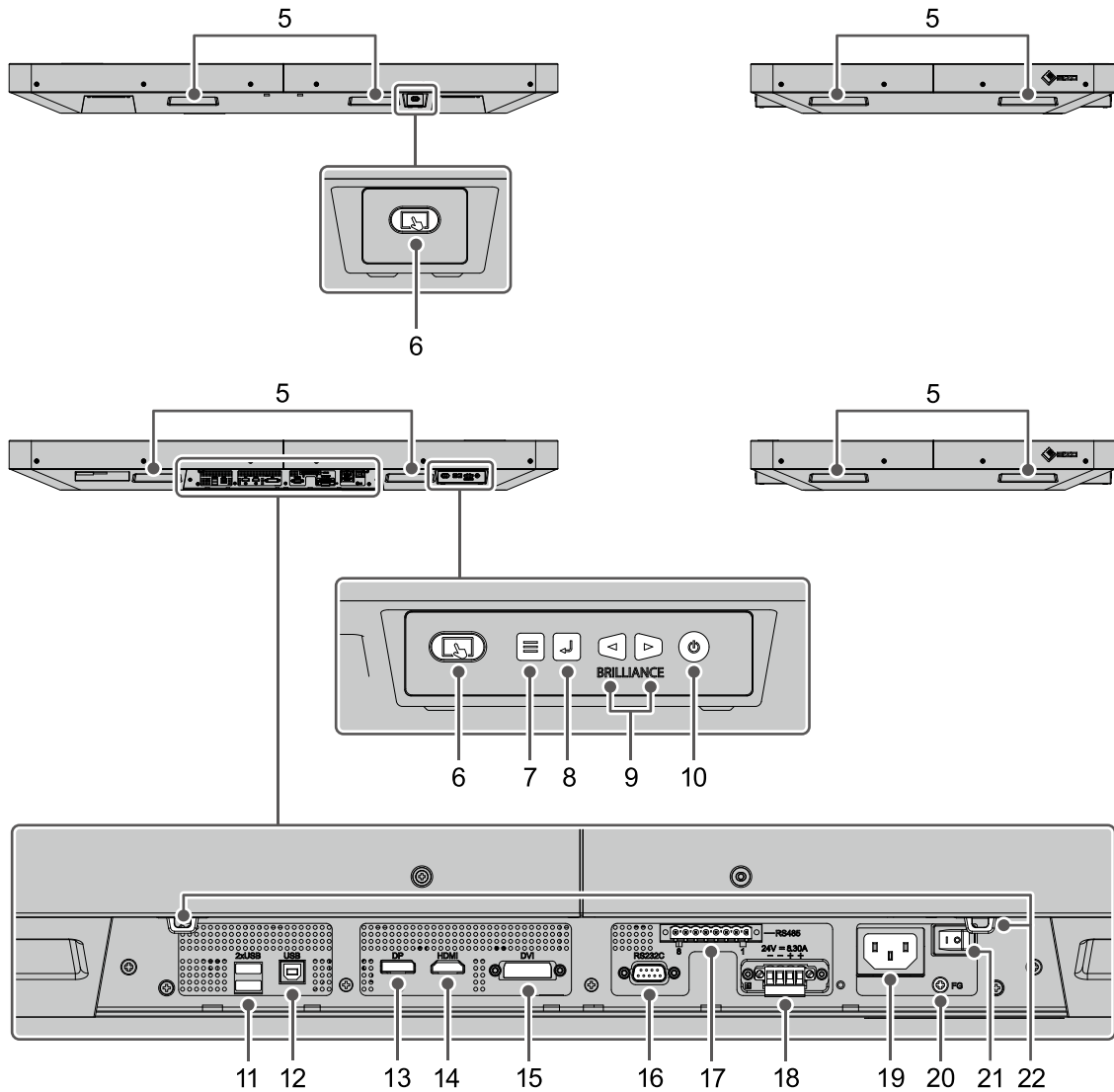

<p>1. ECDIS Indicator</p>	<p>When the monitor brilliance is set to the ECDIS adjustment value, the letters "ECDIS" light up green.</p> <p>Note</p> <ul style="list-style-type: none"> • The ECDIS Indicator will not light up in the following situations: <ul style="list-style-type: none"> - When the ECDIS Indicator is set to "Off" - When Color Mode is set to "Custom" - When the monitor brilliance differs from the ECDIS adjustment value. - When the wrong signal is inputted • While the product can be installed in the range of 0° to 90°, the ECDIS factory shipping adjustment is performed with the monitor in a vertical position.
<p>2. Power lamp</p>	<p>Indicates the operation status of the monitor.</p> <p>When green: Normal operation mode When flickering green: Power saving mode When turned off: Power off</p>
<p>3. Cooling fan</p>	<p>Fans to cool the monitor. Operates when the product interior reaches a high temperature.</p>
<p>4. Buzzer</p>	<p>Can be activated to emit warning beeps by system-side control.</p> <p>Note</p> <ul style="list-style-type: none"> • For details on system-side control, contact your local EIZO representative.

● Side face



5. Handle	Handles for transportation
6.  button	Enables or disables touch panel operation. The button lights up blue when touch panel operation is enabled. Note <ul style="list-style-type: none"> • There are two buttons. You can use either one of them according to the installation position of the monitor. • Touch panel calibration (sensitivity adjustment) can be carried out by holding down the button for two seconds with touch panel operation enabled.
7.  button	Displays the Adjustment menu, or cancels adjustments / settings.
8.  button	Displays the signal name that is currently input. Also confirms an item from the Adjustment menu and saves adjusted values.
9.  buttons	Adjusts the brightness. Also selects Adjustment menu items, and adjusts or configures functions.
10.  button	Turns the power on or off. To turn the power off, hold down  for five seconds or more. The power turns off after the remaining time until it turns off has been displayed.
11. USB downstream port	Connects to a peripheral USB 2.0 device.

12. USB upstream port	Connect a USB cable to this port to: <ul style="list-style-type: none"> • Use the touch panel. • Control the monitor via USB. • Use USB hub function.
13. DisplayPort connector	Inputs DisplayPort signal of a PC.
14. HDMI connector	Inputs HDMI signal of a PC.
15. DVI (DVI-D) connector	Inputs DVI signal of a PC.
16. RS232C port	D-Sub 9-pin (female) connector Use this connector to control the monitor with RS-232C communication.
17. RS485 port	Use this connector to control the monitor with RS-485 communication.
18. DC power connector	Installs the DC power terminal block. A DC power fuse is installed at factory shipment.
19. AC power connector	Connects the power cord. The insulation cover is attached at factory shipment.
20. Functional earth terminal (FG)	A terminal for grounding (functional earth) designed for safe equipment operation. The tapped hole is M4 (4 mm nominal diameter), 6 mm depth.
21. AC main power switch	Turns the AC main power on or off. : On, ○ : Off
22. Cable tie holder	For attaching cable ties used to hold the cables.

Chapter 2 Adjusting Screens

2-1. Adjusting the Brightness

The brightness of the screen can be adjusted to suit the installation environment and/or personal preference.

Adjustable Range

0 % to 100 %

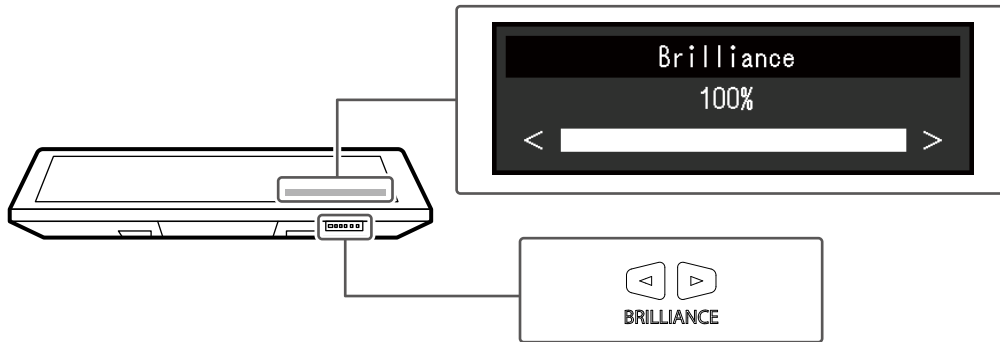

2-2. Switching Input Signals

When a monitor has multiple signal inputs, the signal to display on-screen can be changed.

Procedure

1. Press ↵.
The connector name of the currently displayed signal appears at the bottom right of the screen.
2. Press ◀▶ to switch signals.
3. Press ↵ to apply the change.

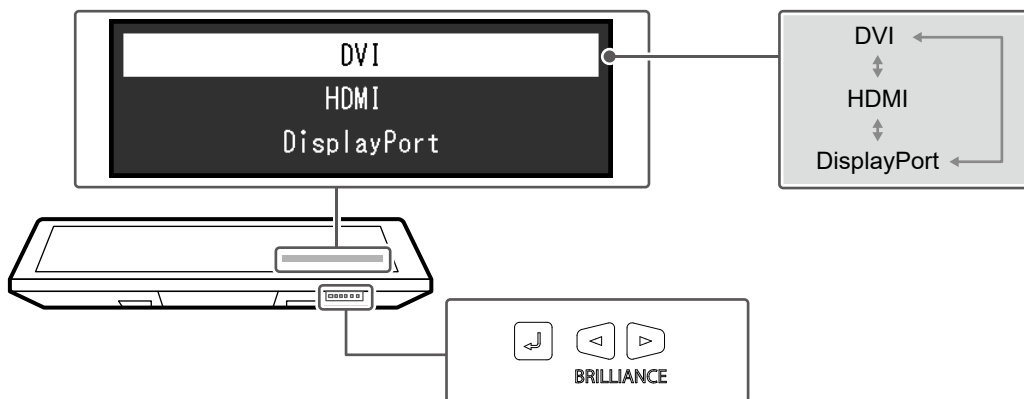

2-3. Configuring Advanced Adjustments / Settings

The Adjustment menu enables you to configure advanced adjustments / settings.

● Basic adjustment menu operations

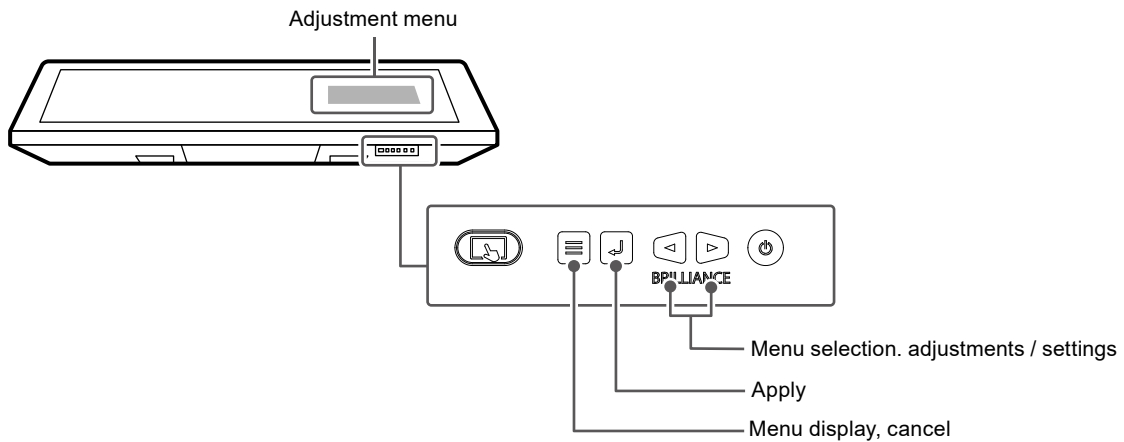

1. Displaying the Adjustment menu

1. Press \equiv to display the Adjustment menu.

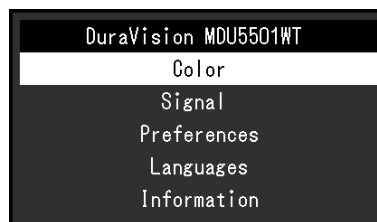

2. Adjusting / Configuring

1. Choose a menu to adjust / configure with $\leftarrow \rightarrow$, and then press \downarrow .

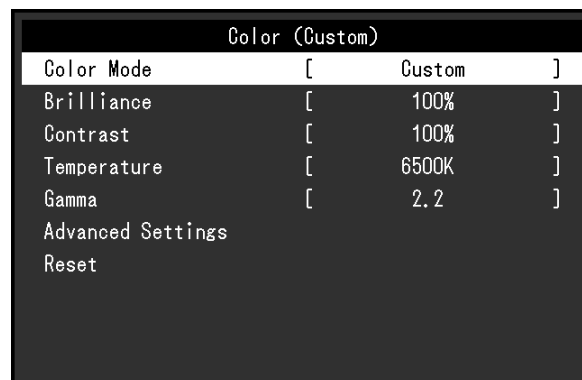

2. Choose an item to adjust / configure with $\leftarrow \rightarrow$, and then press \downarrow .



3. Adjust / set the value with $\leftarrow \rightarrow$, and then press \downarrow to apply the change.

3. Exiting

1. Press \equiv a few times to finish the Adjustment menu.

● Color

When displaying with Custom, each color mode color settings can be adjusted according to personal preference.

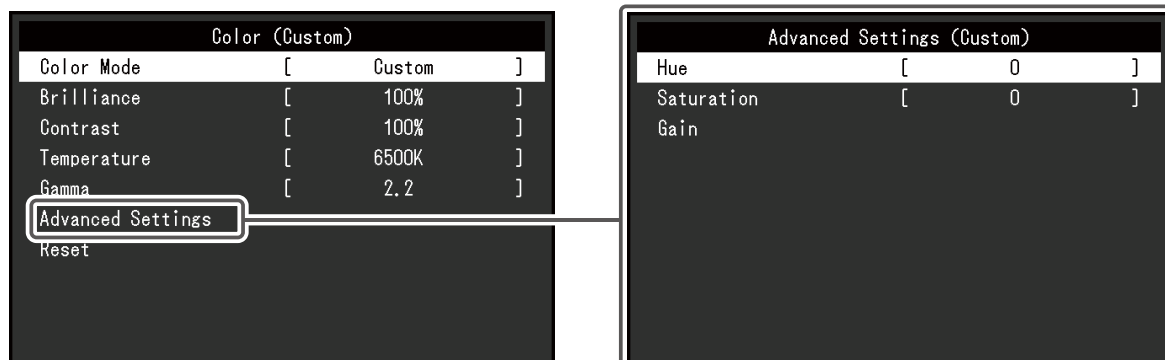

Attention

- The same image may be seen in different colors on multiple monitors due to differences between individual monitors. Make fine color adjustment visually when matching colors on multiple monitors.

Note

- Use the values shown in "%" and "K" as a guide only.

Function	Settings	Description
Color Mode	Custom Day Dusk Night	Switches display modes. Display Mode has three ECDIS Standard compliant modes (Day, Dusk, Night) and a mode where you can make settings of your choice (Custom).
Brilliance	0 % to 100 %	The screen brightness is adjusted by changing the brightness of the backlight (light source from the LCD back panel). Note <ul style="list-style-type: none"> • Can only set to 0% when Backlight Off Mode is set to "On". • Can be set by directly pressing < or > (see "2-1. Adjusting the Brightness" (page 10)). • When adjusting the brilliance by long pressing < or >, reaching the default value stops the adjustment. Press < or > again to continue adjusting (when ECDIS Indicator is set to "On" and Color Mode is set to "Day", "Dusk", or "Night"). Attention <ul style="list-style-type: none"> • Changing to a value other than the default setting makes ECDIS-compliant display not possible.
Contrast*1	0 % to 100 %	Adjusts the difference in brightness between the bright area and the dark area of the screen. Note <ul style="list-style-type: none"> • All of the color gradations can be displayed when Contrast is set to 100 %.



Function		Settings	Description
Temperature ^{*1}		Native 4000 K to 10000 K User	<p>Adjusts the color temperature.</p> <p>The color temperature is used to express the hue of "White". The value is expressed in degrees "K" (Kelvin). The screen becomes reddish at a low color temperature, and bluish at a high color temperature, like the temperature of a flame.</p> <p>Specify a color temperature in units of 100 K, or select "Native".</p> <p>Note</p> <ul style="list-style-type: none"> • When you select "Native", the original color of the LCD monitor (Gain: 100 % for each RGB) is displayed. • "Gain" allows you to perform more advanced adjustment. When gain is changed, the color temperature is changed to "User". • The gain preset values are set for each color temperature setting value.
Gamma ^{*1}		1.6 to 2.7	<p>Adjusts the gamma.</p> <p>The brightness of the monitor varies depending on the input signal, however, the variation rate is not simply proportional to the input signal. The control performed to keep the balance between the input signal and the brightness of the monitor is called "gamma correction".</p>
Advanced Settings ^{*1}	Hue	-100 to 100	<p>Adjusts the hue.</p> <p>Note</p> <ul style="list-style-type: none"> • Using this function may make some color gradations unavailable for display.
	Saturation	-100 to 100	<p>Adjusts the color saturation.</p> <p>Note</p> <ul style="list-style-type: none"> • Using this function may make some color gradations unavailable for display.
	Gain	0 % to 100 %	<p>Adjusts the brightness of each color component red, green, and blue.</p> <p>Note</p> <ul style="list-style-type: none"> • Using this function may make some color gradations unavailable for display. • The gain value changes according to the color temperature. • When gain is changed, the color temperature is changed to "User".
Reset			Returns the color settings to the default state.

^{*1} Available when Color Mode is set to "Custom".

● Signal

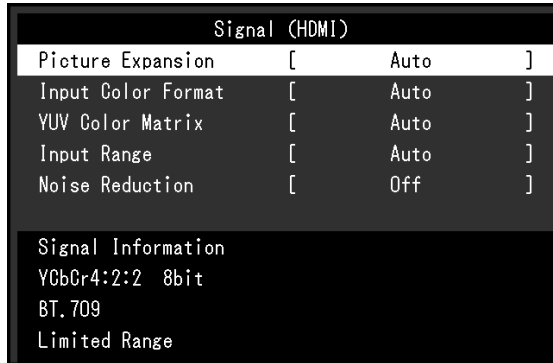
The signal settings are used to configure advanced settings for input signals, such as the screen display size and color format.

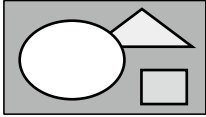
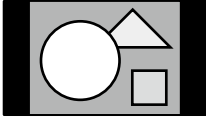

Function	Settings	Description
Picture Expansion	Auto Full Screen Aspect Ratio Dot by Dot	<p>The screen size of the monitor display can be changed.</p> <ul style="list-style-type: none"> "Auto" The monitor automatically changes the screen size according to the resolution information and aspect ratio information from the input signal (only HDMI input enabled). "Full Screen" Displays an image in full screen. Images are distorted in some cases because the vertical rate is not necessarily equal to the horizontal rate. "Aspect Ratio" Displays an image in full screen. However, since aspect ratios are maintained, part of an image may not be visible in horizontal or vertical direction. "Dot by Dot" Displays the image at the set resolution or at the size specified by the input signal. <p>Note</p> <ul style="list-style-type: none"> Example settings <ul style="list-style-type: none"> - Full Screen  - Aspect Ratio  - Dot by Dot (Input Signal) 
Input Color Format	Auto YUV ^{*1} YUV 4:2:2 ^{*2} YUV 4:4:4 ^{*2} RGB	<p>The color space of the input signal can be specified. Try changing this setting if colors are not displayed correctly. Normally, select "Auto".</p> <p>Note</p> <ul style="list-style-type: none"> Compliant with ECDIS standards only when the signal is RGB and "Auto" or "RGB" is selected. This cannot be configured when DVI input is used.

*1 Only enabled during DisplayPort input

*2 Only enabled during HDMI input

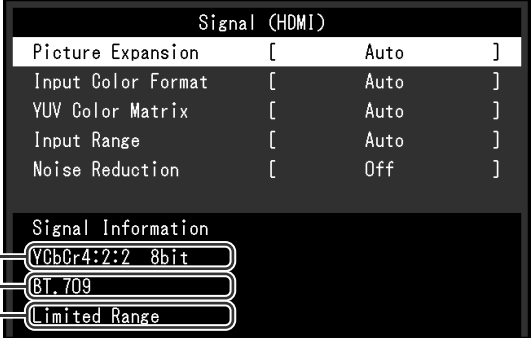
Function	Settings	Description
YUV Color Matrix	Auto BT.601 BT.709 BT.2020	<p>Selects the YUV Color Matrix transformation coefficient. Use when the screen cannot be correctly displayed, such as gradation collapse, due to input signal issues.</p> <p>Note</p> <ul style="list-style-type: none"> This cannot be configured when DVI input is used.
Input Range	Auto Full Limited	<p>Depending on the external device, the black and white levels in the video signal output to the monitor may be restricted. If the signal is displayed on the monitor in its restricted form, the blacks will be faint, the whites dull, and contrast will be reduced. The brightness range of such signals can be extended to match the actual contrast ratio of the monitor.</p> <ul style="list-style-type: none"> "Auto" The monitor automatically recognizes the brightness range of input signals and displays images appropriately. "Full" The input signal brightness range is not extended. "Limited" The brightness range of the input signal is extended from 16 to 235 (10 bits: 64 to 940) to 0 to 255 (10 bits: 0 to 1023) for display. <p>Note</p> <ul style="list-style-type: none"> Compliant with ECDIS standards only when the signal is Full Range and "Auto" or "Full" is selected. This cannot be configured when DVI input is used.
Noise Reduction	On Off	<p>The small noises that occur in dark areas of an image are reduced. Use this function to reduce noise and roughness in images.</p> <p>Note</p> <ul style="list-style-type: none"> This can only be set during HDMI input. When set to the following resolution signals, the function will not work even if set to "On": 1600 × 1200 / 1920 × 2160 / 3840 × 2160 For HDMI-supported resolution, see "6-2. Supported Resolutions" (page 31). Using the Noise Reduction function may lead to deterioration of fine images.
Signal Information	-	<p>The information of the input signal can be verified. The information displayed is as follows:</p> <ol style="list-style-type: none"> Color format, color depth Colorimetry Input range <div style="text-align: center;">  <p>The screenshot shows the OSD menu for Signal (HDMI) settings. The settings are: Picture Expansion [Auto], Input Color Format [Auto], YUV Color Matrix [Auto], Input Range [Auto], and Noise Reduction [Off]. Below this is the Signal Information section, which is highlighted with a white box. It shows three items: 1. YCbCr4:2:2 8bit, 2. BT.709, and 3. Limited Range. Each item is enclosed in a rounded rectangle with a white border.</p> </div> <p>Note</p> <ul style="list-style-type: none"> Depending on the input signal there is information that is not displayed.

● Preferences

The monitor's settings can be configured to suit the usage environment or personal preference.

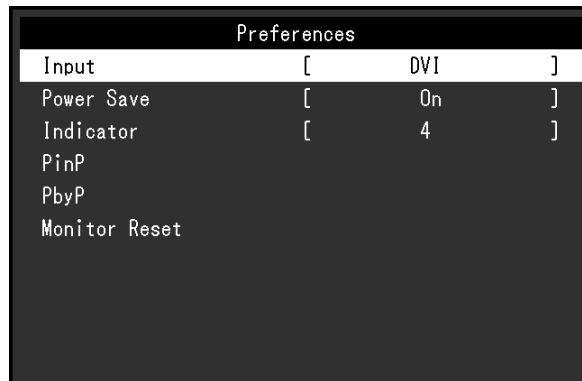

Function		Settings	Description
Input		DVI HDMI DisplayPort	Selects input signal.
Power Save		On Off	This function allows you to set the monitor to the power saving mode, depending on the state of an external device connected to it. The monitor changes to power saving mode about 15 seconds after signal input ceases to be detected. When the monitor has shifted to power saving mode, images are not displayed on the screen. <ul style="list-style-type: none"> Exiting power saving mode <ul style="list-style-type: none"> If the monitor receives input, it automatically exits power saving mode and returns to the normal display mode. <p>Note</p> <ul style="list-style-type: none"> At the time of shifting to power saving mode, a message that indicates the transition is displayed 5 seconds in advance. When you are not using the monitor, set the main power switch to off to cut power consumption. When the monitor is in power saving mode, devices connected to the USB downstream port will still work. Therefore, power consumption of the monitor varies depending on the connected devices, even in the power saving mode.
Indicator		1 to 7	The brightness of the power button and the operation button when the screen is displayed can be set. (Default setting: 4)
PinP	Input	Off DVI HDMI DisplayPort	Selects the input signal for displaying on the sub-monitor when using 2 screen display (PinP). Enabling PbyP turns it Off.
	Position	Upper Right Lower Right Lower Left Upper Left	Selects the display position of the sub-screen.
	Size	Small Medium Large	Selects the size of the sub-screen.
	Resolution	Auto Manual	Selects the resolution of the sub-screen. Selecting "Auto" automatically changes the maximum resolution of the sub-monitor to 1920 × 1080. Selecting "Manual" does not change the sub-monitor resolution. Please change the resolution manually. <p>Note</p> <ul style="list-style-type: none"> Not applicable when using a DVI connector.

Function		Settings	Description
PbyP	Input	Off DVI HDMI DisplayPort	Selects the input signal for displaying on the right monitor when using 2 screen display (PbyP). Enabling PinP turns it Off.
Monitor Reset		OK Cancel	Restore all settings to their default values except for the following settings: <ul style="list-style-type: none"> • Settings in the "Administrator Settings" menu • "Input", "PinP" - "Input" / "Position" / "Size" / "Resolution", "PbyP" - "Input" in the "Preferences" menu. • Enable / Disable Touch Panel Operation

● Languages

The display language for menus and messages can be selected.

Available languages

English, German, French, Spanish, Italian, Swedish, Japanese, Chinese (Simplified), Chinese (Traditional)



● Information

You can check the monitor information (product name, serial number (S/N), usage time) and input signal information.

Example:

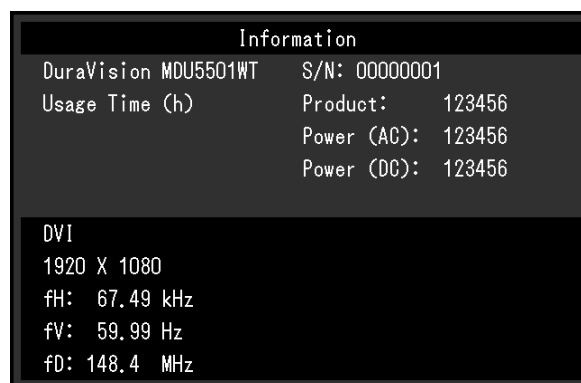



Chapter 3 Administrator Settings

This chapter describes how to configure monitor operation using the "Administrator Settings" menu.

3-1. Basic Operation of the "Administrator Settings" Menu

1. Menu display



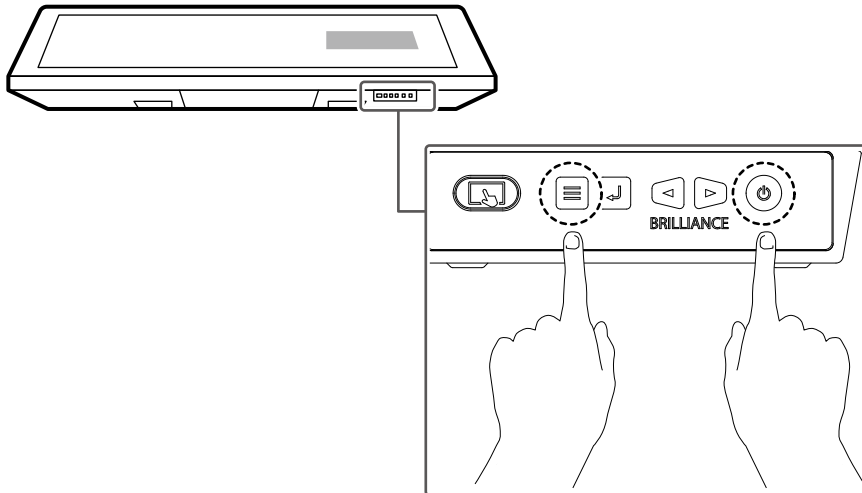



1. Hold down  for five seconds or more to turn off the monitor.
2. Hold down  and press  for two seconds or more to turn on the monitor.



The "Administrator Settings" menu appears.

Administrator Settings		
Auto Input Detection	[Off]
On-Screen Logo	[On]
Key Lock	[Off]
Backlight Off Mode	[Off]
ECDIS Indicator	[On]
RS-232C / RS-485		
Apply		

2. Adjusting / Configuring

1. Choose an item to adjust / configure with  , and then press .
2. Adjust / set the value with  , and then press .

3. Applying and exiting

1. Select "Apply", and then press .
- The settings are confirmed and the "Administrator Settings" menu quits.

3-2. "Administrator Settings" Menu Functions

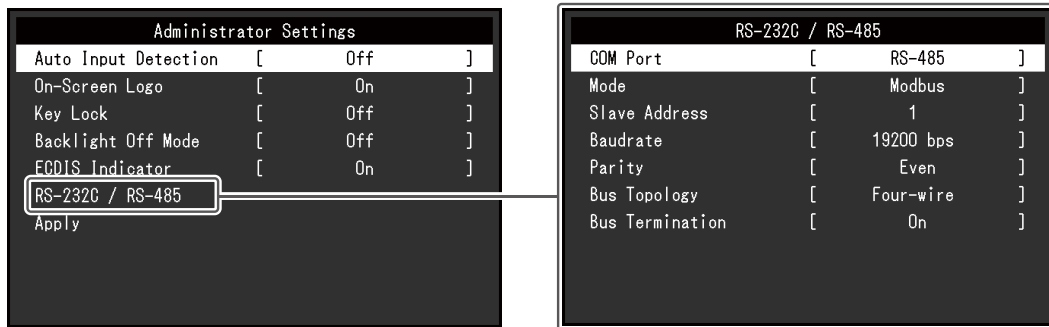

Function	Settings	Description
Auto Input Detection	Off On	<p>When this function is set to "On", the monitor automatically recognizes the connector through which signals are input, so that the screen can be displayed. When the selected connector input signal disappears another signal automatically displays.</p> <p>When set to "Off", the monitor displays the signal from the selected connector regardless of whether a signal is input or not. In this case, select the input signal to display using the operation button (↵) on the side of the monitor (side with the power connector).</p> <p>Note</p> <ul style="list-style-type: none"> • Sets to "Off" when using two screens (PinP or PbyP).
On-Screen Logo	Off On	<p>When this function is set to "Off", the EIZO logo that displays when turning on the product does not appear.</p>
Key Lock	Off Menu All	<p>In order to prevent changes to settings, the operation buttons on the side of the monitor (side with the power connector) can be locked.</p> <ul style="list-style-type: none"> • "Off" (default setting) All buttons are enabled. • "Menu" Lock the ≡ button. • "All" Lock all switches except the power switch. <p>Note</p> <ul style="list-style-type: none"> • When locked, using the buttons will display "Locked" on the screen.
Backlight Off Mode	Off On	<p>When "On", setting Brilliance to the lower limit turns off the backlight, making the screen dark. (Excluding when the adjustment menu, input signal error, or EIZO logo are displayed)</p> <p>When "Off", setting Brilliance to the lower limit does not make the screen dark.</p>
ECDIS Indicator	On Off	<p>Setting this function to "On" will light up the ECDIS Indicator.</p> <p>Note</p> <ul style="list-style-type: none"> • The ECDIS Indicator will not light up in the following situations: <ul style="list-style-type: none"> - When the ECDIS Indicator is set to "Off" - When Color Mode is set to "Custom" - When the monitor brilliance differs from the ECDIS adjustment value. - When the wrong signal is inputted

Function		Settings	Description
RS-232C / RS-485	COM Port	RS-232C RS-485	Selects the COM port used for monitor control.
	Mode	Modbus ECOM	Selects communication mode.
	Slave Address ^{*1}	1 to 247 ^{*3}	Specifies a slave address.
	Baudrate ^{*1, *2}	19200 bps 9600 bps	Specifies the transmission rate.
	Parity ^{*1, *2}	Even Odd None	Specifies the parity check method.
	Bus Topology ^{*1}	Four-wire Two-wire	Selects half-duplex communication or full-duplex communication.
	Bus Termination ^{*1}	On Off	Set this to "Off" if a terminating device is installed on the communication path.



*1 Available when COM Port is set to "RS-485".

*2 Available when Mode is set to "Modbus".

*3 When Mode is "ECOM", the setting range is 0 to 15.

Chapter 4 Troubleshooting



4-1. No Picture



Problem	Possible cause and remedy
<p>1. No picture</p> <ul style="list-style-type: none"> None of the operation buttons light up. 	<ul style="list-style-type: none"> Check whether the power cord is connected properly. Turn the main power switch on. Turn off the main power, and then turn it on again a few minutes later. If the monitor is used in a low temperature environment, leave the monitor for a while with the power turned on, then turn the power off and on.
<ul style="list-style-type: none"> Only the  button lights up green. 	<ul style="list-style-type: none"> Press .
<ul style="list-style-type: none"> All operation buttons light up green or the  button blinks green. 	<ul style="list-style-type: none"> Adjust the brightness (brilliance) of the screen. Move the mouse or press any key on the keyboard. Check whether the PC is turned on. Switch the input signal (see “2-2. Switching Input Signals” (page 10)).
<p>2. Messages like the ones below appear.</p>	<p>This message appears when the signal is not input correctly even when the monitor is functioning correctly.</p>
<ul style="list-style-type: none"> This message appears when no signal is input. Example: <div data-bbox="285 1160 657 1294" style="border: 1px solid black; background-color: black; color: white; padding: 10px; text-align: center;"> <p>DVI No Signal</p> </div>	<ul style="list-style-type: none"> The message shown left may appear, because some PCs do not output the signal immediately after the power turns on. Check whether the PC is turned on. Check whether the signal cable is connected properly. Switch the input signal (see “2-2. Switching Input Signals” (page 10)).
<ul style="list-style-type: none"> The message shows that the input signal is out of the frequency specification range. Example: <div data-bbox="285 1440 657 1574" style="border: 1px solid black; background-color: black; color: white; padding: 10px; text-align: center;"> <p>DVI Signal Error</p> </div>	<ul style="list-style-type: none"> Check whether the PC is configured to meet the resolution and vertical scan frequency requirements of the monitor (see “6-2. Supported Resolutions” (page 31)). Reboot the PC. Select an appropriate display mode using the graphics board's utility. Refer to the User's Manual of the graphics board for details.

4-2. Imaging Problems

Problem	Possible cause and remedy
1. The screen is too bright or too dark.	<ul style="list-style-type: none"> Use "Brilliance" in the Adjustment menu to adjust it. (The LCD monitor backlight has a limited life span. If the screen becomes dark or begins to flicker, contact your local EIZO representative.)
2. The screen suddenly became dark. / It cannot be made brighter even by increasing the "Brilliance" value in the Adjustment menu.	<ul style="list-style-type: none"> The product always monitors its internal temperature. If the internal temperature becomes high and exceeds a certain level, brightness may be reduced to bring the temperature down. In this case, the brightness level cannot be set to be higher than a controlled level. This state will return to the original when the internal temperature falls. If the internal temperature becomes even higher, the power to the monitor is automatically turned off.
3. Characters are blurred.	<ul style="list-style-type: none"> Check whether the PC is configured to meet the resolution and vertical scan frequency requirements of the monitor (see "6-2. Supported Resolutions" (page 31)). For information on how to change your PC settings, please visit our website (www.eizoglobal.com).
4. Afterimages appear	<ul style="list-style-type: none"> Afterimages are particular to LCD monitors. Avoid displaying the same image for a long time. Use the screen saver or power saving function to avoid displaying the same image for extended periods of time. An afterimage may appear even after a short time period has elapsed depending on the displayed image. If this occurs, changing the image or leaving the power off for a few hours may solve the problem.
5. Green / red / blue / white dots or defective dots remain on the screen.	<ul style="list-style-type: none"> This is due to LCD panel characteristics and not a malfunction.
6. Interference patterns or pressure marks remain on the screen.	<ul style="list-style-type: none"> Display a white or black image over the entire screen. The symptom may disappear.
7. Cloudiness cannot be removed even after wiping the screen. / There is dew on the interior side of the glass.	<ul style="list-style-type: none"> When cloudiness cannot be removed even after wiping the screen, dew may have formed on the interior side of the glass that protects the LCD panel. In this case, turn on the monitor and display something on screen. The dew will disappear after a while. Also, warming the glass using a hair dryer may make the dew disappear more quickly. Dew appearing like this on the interior side of the glass will not lead to product failure or degradation.

4-3. Touch Panel Problems

Problem	Possible cause and remedy
<p>1. Touch is not working.</p>	<ul style="list-style-type: none"> • Touch panel operation may be disabled. Press the  button to enable it. The  button lights up blue. • Check that the monitor and PC are connected with a USB cable. • Turn the monitor off and on. • This product automatically disables touch panel operations when moisture or any other objects (including styluses and smartphones) that may cause a malfunction are detected on the touch panel surface. (Water Detection Function) Remove water or objects on the touch panel if the following message is displayed (see “Cleaning” (page 4)): <div data-bbox="821 669 1278 757" style="background-color: #333; color: #fff; padding: 5px; text-align: center; margin: 10px 0;"> <p>Water or other substance detected. Touch input not available.</p> </div> <ul style="list-style-type: none"> • Wait a while before resuming operation. • Check that the power cord of the monitor and PC is connected to a grounded main outlet. Failure to ground the equipment may result in a malfunction. • Check that fluorescent lights and other sources of noise are not installed nearby. Malfunction may occur if there are sources of noise installed close by. • Hold down  for two seconds or more to perform touch panel sensitivity adjustment. Do not touch the touch panel until the message "Don't touch the panel. Calibrating..." disappears from the screen. • Perform touch panel sensitivity adjustment using TPOffset. • If two or more PCs are connected to the monitor, only one of them can perform touch operations. Check that the monitor and PC used for touch operations are connected with a USB cable.

Problem	Possible cause and remedy
<p>2. Cursor position is not correct. / Cursor jumps.</p>	<ul style="list-style-type: none"> • Connect the monitor to the PC with the cable indicated in the Setup Manual. The touch panel may not work correctly if a conversion adapter is used. • Turn the monitor off and on. • Hold down  for two seconds or more to perform touch panel sensitivity adjustment. Do not touch the touch panel until the message "Don't touch the panel. Calibrating..." disappears from the screen. • Check that the power cord of the monitor and PC is connected to a grounded main outlet. Failure to ground the equipment may result in a malfunction. • Perform touch panel sensitivity adjustment using TPOffset. • Changing the position or angle of the monitor may cause the cursor to jump. • Keep metals away from the touch panel surface as they may lead to incorrect cursor positioning. • If the touch panel is dirty, the touch panel may not operate properly. Clean the touch panel surface (see "Cleaning" (page 4)). • The spray for preventing static electricity may affect the sensitivity of the touch panel and cursor positioning. • Do not touch the touch panel for five seconds after the PC starts up, after turning on the monitor, or after connecting the cable. Touching the touch panel too soon may cause incorrect cursor positioning or disable touch operations. If this occurs, either refrain from touching the touch panel for approximately two minutes, or turn the monitor off and on again. If the problem persists, calibrate the screen again. • When displaying at a resolution other than the recommended resolution, the touch position and cursor position may shift due to the scaling function of the graphics board. In that case, check the graphics driver settings and change the scaling to the monitor. After changing the settings, perform calibration again.
<p>3. The cursor does not appear at the touched position and instead is displayed at a point-symmetric position with respect to the center of the screen.</p>	<ul style="list-style-type: none"> • Calibrate the screen again.
<p>4. Cursor is jittery. / Lines drawn are not straight and smooth.</p>	<ul style="list-style-type: none"> • Check that the power cord of the monitor and PC is connected to a grounded main outlet. Failure to ground the equipment may result in a malfunction. • Hold down  for two seconds or more to perform touch panel sensitivity adjustment. Do not touch the touch panel until the message "Don't touch the panel. Calibrating..." disappears from the screen. • Perform touch panel sensitivity adjustment using TPOffset. • Cursor may be jittery under the interference of metal. • Leave space between monitors when multiple monitors are placed close to each other.

Problem	Possible cause and remedy
5. Calibration does not work correctly.	<ul style="list-style-type: none"> Hold down  for two seconds or more to perform touch panel sensitivity adjustment. Do not touch the touch panel until the message "Don't touch the panel. Calibrating..." disappears from the screen. Perform touch panel sensitivity adjustment using TPOffset.
6. No touch sound is heard.	<ul style="list-style-type: none"> If you have set touch sound to be output through the audio output terminal of the PC, connect speakers. Install DMT-DD and configure necessary settings. For details, refer to the DMT-DD User's Manual (in the CD-ROM). Touch sound cannot be heard when Windows standard driver is used.

Attention

- For details on TPOffset (software used to adjust the sensitivity of the touch panel), see the TPOffset User's Manual (in the CD-ROM).

4-4. Other Problems

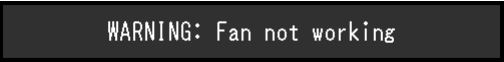
Problem	Possible cause and remedy
<p>1. The message below appears on screen.</p> 	<ul style="list-style-type: none"> This message appears when the monitor's cooling fan is not operating correctly. Check the state of the cooling fan on the rear of the monitor. To replace the fan, see "5-1. How to replace the cooling fan" (page 26).
2. The Adjustment menu does not appear.	<ul style="list-style-type: none"> Check whether the lock function of the Adjustment menu or operation button works (see "Key Lock" (page 30)).
3. The fan is noisy.	<ul style="list-style-type: none"> This product is fitted with cooling fans to keep the internal temperature from rising. Depending on the monitor's location, fan noise may be audible when they are operating.

Chapter 5 Maintenance

5-1. How to replace the cooling fan

Attention

- Be sure to follow the procedure when replacing the fan. Note that EIZO Corporation assumes no responsibility for any damage caused due to incorrect handling of this product.

Note

- Please contact your local EIZO representative for replacement parts.

1. Disconnect the AC power cord and DC power terminal block.

2. Remove the fan cover and fan holder.

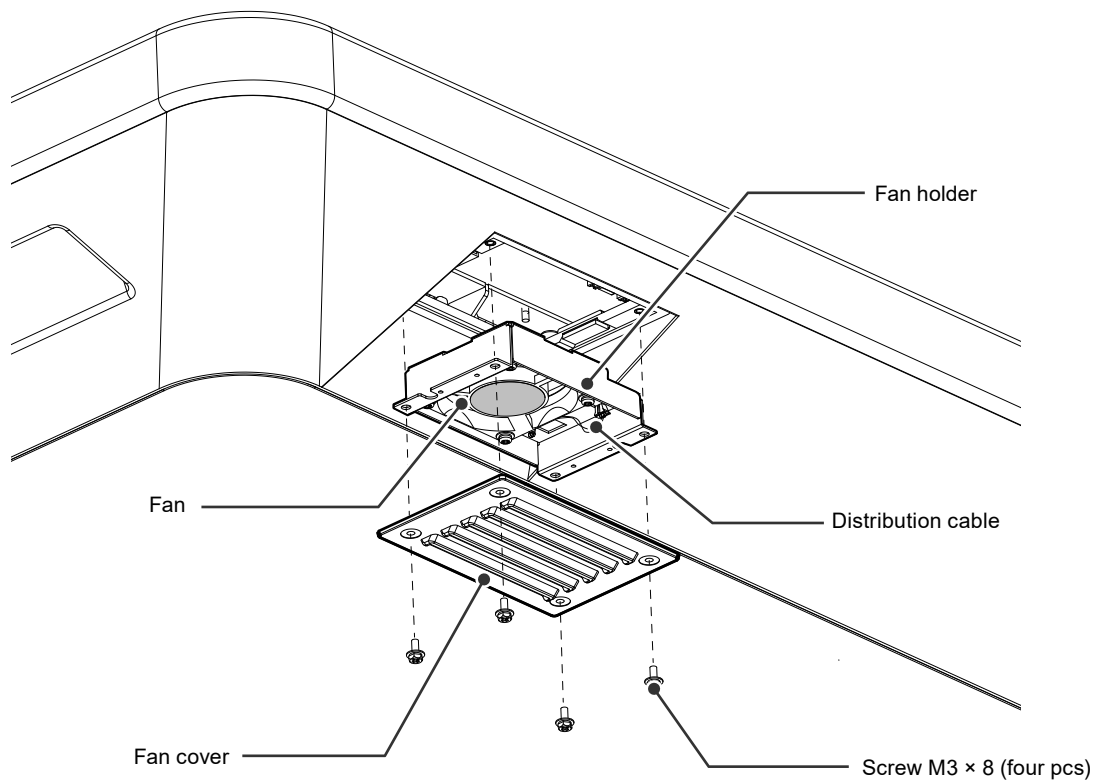

1. Remove the screws (four pcs) that secure the cover.
Use a box-end wrench with 3 mm nominal diameter (with offset) to remove the screws.
2. Remove the cover.
3. Disconnect the distribution cable connected to the monitor.
4. Remove the holder.
The holder is temporarily attached to the monitor using a face fastener.

Attention

- Hold the connector when removing the distribution cable. Pulling on the distribution cable may damage the connector.

3. Remove the fan from the fan holder.

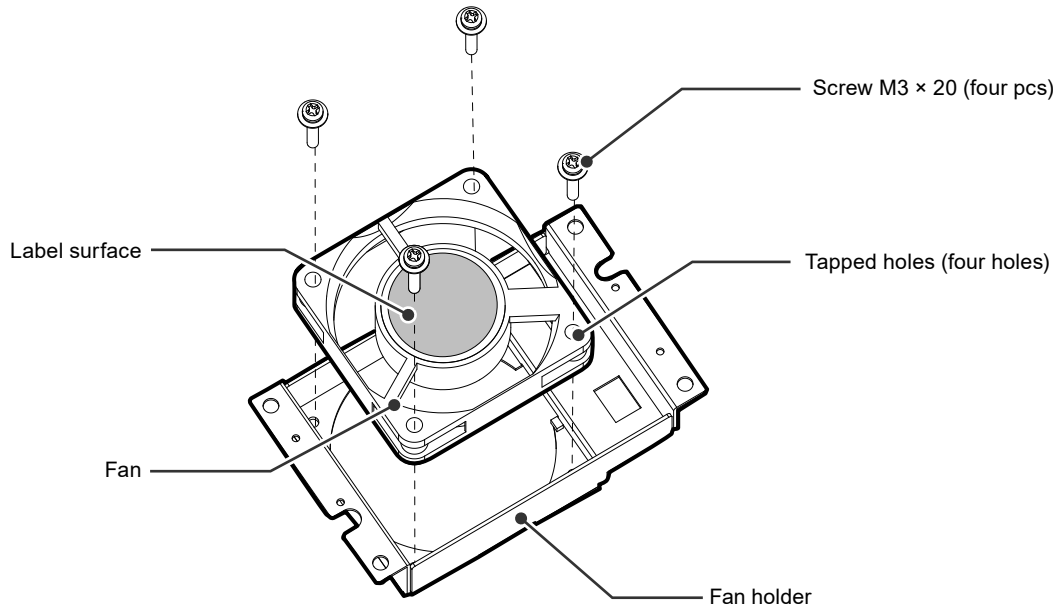

1. Remove the screws (four pcs) that secure the fan.
Use a Phillips screwdriver to remove the screws.
2. Remove the fan.

4. Install a new fan in the fan holder.

Attention

- Handle the fan with care. Dropping or subjecting the fan to physical shock may damage it.
 - Pay attention to the orientation of the fan when installing it.
-

1. Attach the fan to the holder using the screws removed in step 3 ([page 27](#)) (recommended torque: $0.78 \pm 0.2 \text{ N}\cdot\text{m}$). Install the fan so that its label surface is oriented outwards.

5. Install the fan holder and fan cover.

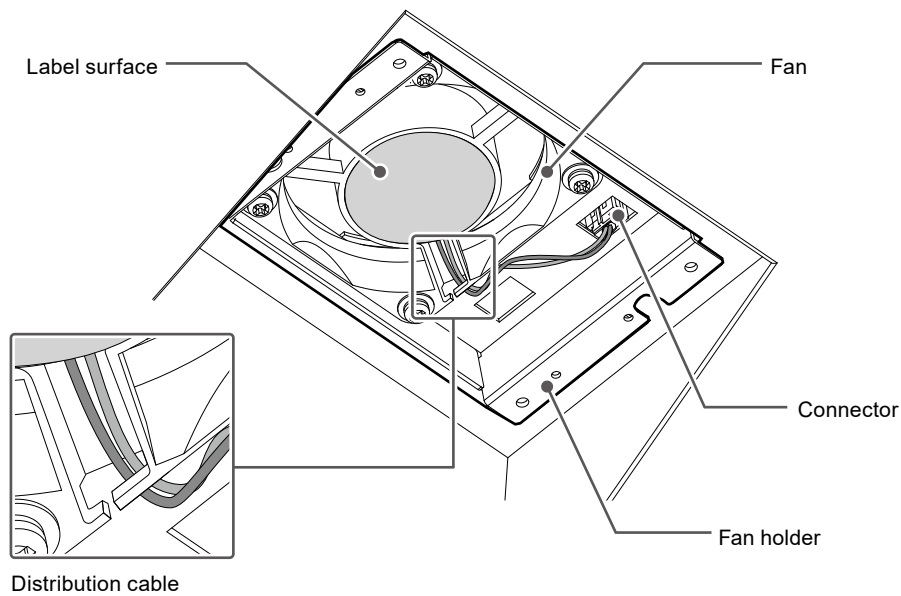

1. Install the holder on the monitor.
2. Connect the distribution cable to the monitor. Ensure the connector is connected to the monitor.
3. Route the distribution cable through the gap of the fan.
4. Fix the cover to the monitor using the screws removed in step 2 ([page 26](#)).

Note

- After replacing the fan, perform the following procedure to check the operation:
 1. Confirm that the fan is rotating.
 2. Check that the message "WARNING: Fan not working" is not displayed on the screen.

WARNING: Fan not working

5-2. Periodic check of buzzer alarm

- The buzzer installed in this monitor can be activated to emit warning beeps by system-side control.
- Check periodically to ensure that the warning beeps of the buzzer work. Use system-side control to check the buzzer.

Note

- For details on system-side control, contact your local EIZO representative.
-

Chapter 6 Reference

6-1. Specifications

LCD Panel	Type	VA		
	Backlight	LED		
	Size	138.8 cm (54.6 inch)		
	Resolution	3840 dots × 2160 lines		
	Display Size (H × V)	1209.6 mm × 680.4 mm		
	Pixel Pitch	0.315 mm × 0.315 mm		
	Display Colors	Approx. 16.77 million colors		
	Viewing Angles (H / V) (typical)	178° / 178°		
	Maximum brightness (brilliance) (typical)	610 cd/m ²		
	Contrast Ratio (typical)	4000:1		
	Response Time (typical)	Gray-to-gray: 8 ms		
Touch Panel	Method	Projected capacitive technology		
	Transfer method	USB transfer		
	Surface treatment	Anti-glare, Anti-fingerprint		
	Surface hardness	5H		
	OS supported ^{*1}	Windows 11 (64 bit) Windows 10 (32 bit / 64 bit) Windows 8.1 (32 bit / 64 bit) (Not compatible with Mac)		
	Number of simultaneous touch points	10 points		
Video Signals	Terminals	DisplayPort (HDCP-compatible) × 1 HDMI (HDCP-compatible) × 1 DVI-D (Single Link) × 1		
	Digital scanning frequency (H)	DisplayPort: 31 kHz to 135 kHz HDMI: 31 kHz to 135 kHz DVI-D: 31 kHz to 75 kHz		
	Digital scanning frequency (V)	DisplayPort: 29 Hz to 61 Hz (720 × 400: 69 Hz to 71 Hz) HDMI: 29 Hz to 61 Hz (720 × 400: 69 Hz to 71 Hz) DVI-D: 59 Hz to 61 Hz (720 × 400: 69 Hz to 71 Hz)		
	Dot clock (Max.)	DisplayPort / HDMI: 599 MHz DVI-D: 164 MHz		
Communication	Terminals	RS-232C:	D-Sub 9-pin (female)	
		RS-485:	Terminal block (8-pin)	
USB	Port	Upstream port × 1 Downstream port × 2		
	Standard	USB Specification Rev. 2.0		
Power	Power Input	AC	100 - 240 V +10% / -15%, 50 / 60 Hz, 2.00 - 1.00 A	
		DC	24 V +30% / -10%, 8.30 A	
	Maximum Power Consumption	AC	195 W or less	
		DC	199 W or less	
	Power Save Mode	AC	20 W or less	(DisplayPort input only, USB device not connected)
		DC	15 W or less	
Standby Mode	AC	20 W or less	(No input signal, USB device not connected)	
	DC	15 W or less		
Physical Specifications	Outside Dimensions	1334 mm × 888 mm × 121 mm (W × H × D)		
	Net. weight	Approx. 71.7 kg		
Operating Environment Requirements	Temperature	-15°C to 55°C ^{*2}		
	Humidity	10% to 90% (R.H., non-condensing) ^{*3}		
Non-Operating Environment Requirements	Temperature	-20°C to 60°C ^{*2}		
	Humidity	10% to 90% (R.H., non-condensing) ^{*3}		

Transportation / Storage Environmental Requirements	Temperature	-20°C to 60°C*2
	Humidity	10% to 92% (R.H., non-condensing)*3
Viewing distance (Recommended)		1086 mm or more (*Based on IEC 62288)
Protection structure		Front: IP65 Back / Side: IP22

*1 Our support will end when the OS manufacturer's support ends.

*2 Stylus 0°C to 45°C

*3 Stylus 20% to 75%

● Main default settings

Color Mode	Custom
Brilliance	Custom: 100% Day: 71% Dusk: 55% Night: 31%
Contrast	100%
Temperature	6500 K
Gamma	2.2
Hue	0
Saturation	0
Picture Expansion	DVI: Aspect Ratio HDMI: Auto DisplayPort: Aspect Ratio
Power Save	On
Indicator	4
Languages	English
Auto Input Detection	Off
On-Screen Logo	On
Key Lock	Off
Backlight Off Mode	Off
ECDIS Indicator	On

6-2. Supported Resolutions

The monitor supports the following resolutions:

√: Supported -: Not supported

Resolution	Vertical scan frequency (Hz)	DisplayPort			HDMI			DVI		
		1 screen	PinP	PbyP	1 screen	PinP	PbyP	1 screen	PinP	PbyP
640 × 480	59.940	√	√	√	√	√	√	√	√	√
640 × 480	60.000	√	√	√	√	√	√	√	√	√
720 × 400	70.087	√	√	√	√	√	√	√	√	√
720 × 480	59.941	√	√	√	√	√	√	√	√	√
720 × 480	59.940	√	√	√	√	√	√	-	-	-
720 × 480	60.000	√	√	√	√	√	√	-	-	-
800 × 600	60.317	√	√	√	√	√	√	√	√	√
1024 × 768	60.004	√	√	√	√	√	√	√	√	√
1280 × 960	60.000	√	√	√	√	√	√	√	√	√
1280 × 1024	60.020	√	√	√	√	√	√	√	√	√
1280 × 720	59.940	√	√	√	√	√	√	√	√	√
1280 × 720	60.000	√	√	√	√	√	√	√	√	√
1600 × 1200	60.000	√	√	√	√	√	√	√	√	√
1680 × 1050	59.883	√	√	√	√	√	√	√	√	√
1680 × 1050	59.954	√	√	√	√	√	√	√	√	√
1920 × 1080	29.970	√	√	√	√	√	√	-	-	-
1920 × 1080	30.000	√	√	√	√	√	√	-	-	-
1920 × 1080	59.940	√	√	√	√	√	√	√	√	√
1920 × 1080	59.963	√	√	√	√	√	√	-	-	-
1920 × 1080	60.000	√	√	√	√	√	√	√	√	√
1920 × 2160	59.988	-	-	√	-	-	√	-	-	-
2560 × 1440	59.951	√	-	-	-	-	-	-	-	-
3840 × 2160 ^{*1}	29.970	√	-	-	√	-	-	-	-	-
3840 × 2160 ^{*1}	29.981	√	-	-	-	-	-	-	-	-
3840 × 2160 ^{*1}	30.000	√	-	-	√	-	-	-	-	-
3840 × 2160 ^{*1}	59.940	√	-	-	√	-	-	-	-	-
3840 × 2160 ^{*1}	59.997	√	-	-	-	-	-	-	-	-
3840 × 2160 ^{*1}	60.000	√	-	-	√	-	-	-	-	-

*1 Recommended resolution

Note

- Only supports progressive scan method.

Appendix

Trademark

The terms HDMI and HDMI High-Definition Multimedia Interface, and the HDMI Logo are trademarks or registered trademarks of HDMI Licensing, LLC in the United States and other countries.

The DisplayPort Compliance Logo and VESA are registered trademarks of the Video Electronics Standards Association.

The SuperSpeed USB Trident Logo is a registered trademark of USB Implementers Forum, Inc.



The USB Power Delivery Trident Logos are trademarks of USB Implementers Forum, Inc.



DICOM is the registered trademark of the National Electrical Manufacturers Association for its standards publications relating to digital communications of medical information.

Kensington and Microsaver are registered trademarks of ACCO Brands Corporation.

Thunderbolt is a trademark of Intel Corporation in the United States and/or other countries.

Microsoft and Windows are registered trademarks of Microsoft Corporation in the United States and other countries.

Adobe is a registered trademark of Adobe Systems Incorporated in the United States and other countries.

Apple, macOS, Mac OS, OS X, Macintosh and ColorSync are registered trademarks of Apple Inc.

Ethernet is a registered trademark of Fuji Xerox Co., Ltd.

EIZO, the EIZO Logo, ColorEdge, CuratOR, DuraVision, FlexScan, FORIS, RadiCS, RadiForce, RadiNET, Raptor and ScreenManager are registered trademarks of EIZO Corporation in Japan and other countries.

ColorEdge Tablet Controller, ColorNavigator, EcoView NET, EIZO EasyPIX, EIZO Monitor Configurator, EIZO ScreenSlicer, G-Ignition, i•Sound, Quick Color Match, RadiLight, Re/Vue, SafeGuard, Screen Administrator, Screen InStyle, ScreenCleaner and UniColor Pro are trademarks of EIZO Corporation.

All other company names, product names, and logos are trademarks or registered trademarks of their respective owners.

License

The bitmap font used for this product is designed by Ricoh Industrial Solutions Inc.

Testing Standard

This product complies with the IEC60945 4th edition standard.

Equipment category: b) protected from the weather

Type Approval of Ship Classification

This product is pending approval for the following types of ship classifications.

- NK (Nippon Kaiji Kyokai)
- DNV (DNV AS)
- ABS (American Bureau of Shipping)
- LR (Lloyd's Register of Shipping)

* For the latest information on approvals for ship classifications, please refer to our website.
www.eizoglobal.com

Other Certifications

This device is expected to obtain an EU RO MR TAC (European Union Recognition Organization Mutual Recognition Type Approval Certificate).

*For current status, please refer to our website. www.eizoglobal.com

Attention

- The stylus and stylus holder are not covered by test standards, classification type approvals, or any other standards.

Warning for Radio interference

For Europe, etc Only

Warning

Operation of this equipment in a residential environment could cause radio interference.

Warnung

Der Betrieb dieses Geräts in einer Wohnumgebung konnte Funkstörungen verursachen.

Avertissement

L'utilisation de cet équipement dans une zone résidentielle pourrait provoquer des interférences radio.

Attention

- The above warnings are not applicable to the stylus and stylus holder.

LIMITED WARRANTY

EIZO Corporation (hereinafter referred to as “EIZO”) and distributors authorized by EIZO (hereinafter referred to as the “Distributors”) warrant, subject to and in accordance with the terms of this limited warranty (hereinafter referred to as the “Warranty”), to the original purchaser (hereinafter referred to as the “Original Purchaser”) who purchased the product specified in this document (hereinafter referred to as the “Product”) from EIZO or Distributors, that EIZO and Distributors shall, at their sole discretion, either repair or replace the Product at no charge if the Original Purchaser becomes aware within the Warranty Period (defined below) that the Product malfunctions or is damaged in the course of normal use of the Product in accordance with the description in the instruction manual of the Product (hereinafter referred to as the “User’s Manual”).

The period of this Warranty is three (3) years from the date of purchase of the Product (hereinafter referred to as the “Warranty Period”). However, the Warranty Period of the main body of the stylus is two (2) years from the date of purchase. EIZO and Distributors shall bear no liability or obligation with regard to the Product in relation to the Original Purchaser or any third parties other than as provided under this Warranty.

EIZO and Distributors will cease to hold or store any parts (excluding design parts) of the Product upon expiration of ten (10) years after the production of the Product is discontinued. In repairing the monitor, EIZO and Distributors will use renewal parts which comply with our QC standards. If the unit cannot be repaired due to its condition or the stockout of a relevant part, EIZO and Distributors may offer the replacement by a product with equivalent performance instead of repairing it.

The Warranty is valid only in the countries or territories where the Distributors are located. The Warranty does not restrict any legal rights of the Original Purchaser.

Notwithstanding any other provision of this Warranty, EIZO and Distributors shall have no obligation under this Warranty whatsoever in any of the cases as set forth below:

- (a) Any defect of the Product caused by freight damage, modification, alteration, abuse, misuse, accident, incorrect installation, disaster, adherent dust, faulty maintenance and/or improper repair by third party other than EIZO and Distributors;
- (b) Any incompatibility of the Product due to possible technical innovations and/or regulations;
- (c) Any deterioration of the sensor, including measurement value of the sensor;
- (d) Any defect of the Product caused by external equipments;
- (e) Any defect of the Product caused by the use under environmental conditions other than EIZO and Distributors’ estimation;
- (f) Any deterioration of the attachments of the Product (e.g. cables, User’s Manual, CD-ROM, etc.);
- (g) Any deterioration of the consumables, and/or accessories of the Product (e.g. batteries, remote controller, touch pen, etc.);
- (h) Any deformation, discoloration, and/or warp of the exterior of the Product including that of the surface of the LCD panel;
- (i) Any defect of the Product caused by placement in a location where it may be affected by strong vibration or shocks;
- (j) Any defect of the Product caused by liquid leaking from battery;
- (k) Any deterioration of display performance caused by the deterioration of expendable parts such as the LCD panel and/or backlight, etc. (e.g. changes in brightness, changes in brightness uniformity, changes in color, changes in color uniformity, defects in pixels including burnt pixels, etc.);
- (l) Any deterioration or malfunction of the cooling fan caused by adherent dust.

To obtain service under the Warranty, the Original Purchaser must deliver the Product, freight prepaid, in its original package or other adequate package affording an equal degree of protection, assuming the risk of damage and/or loss in transit, to the local Distributor. The Original Purchaser must present proof of purchase of the Product and the date of such purchase when requesting services under the Warranty.

The Warranty Period for any replaced and/or repaired product under this Warranty shall expire at the end of the original Warranty Period.

EIZO OR DISTRIBUTORS ARE NOT RESPONSIBLE FOR ANY DAMAGE TO, OR LOSS OF, DATA OR OTHER INFORMATION STORED IN ANY MEDIA OR ANY PART OF ANY PRODUCT RETURNED TO EIZO OR DISTRIBUTORS FOR REPAIR.

EIZO AND DISTRIBUTORS MAKE NO FURTHER WARRANTIES, EXPRESSED OR IMPLIED, WITH RESPECT TO THE PRODUCT AND ITS QUALITY, PERFORMANCE, MERCHANTABILITY OR FITNESS FOR ANY PARTICULAR USE. IN NO EVENT SHALL EIZO OR DISTRIBUTORS BE LIABLE FOR ANY INCIDENTAL, INDIRECT, SPECIAL, CONSEQUENTIAL OR OTHER DAMAGE WHATSOEVER (INCLUDING, WITHOUT LIMITATION, DAMAGES FOR LOSS OF PROFIT, BUSINESS INTERRUPTION, LOSS OF BUSINESS INFORMATION, OR ANY OTHER PECUNIARY LOSS) ARISING OUT OF THE USE OR INABILITY TO USE THE PRODUCT OR IN ANY CONNECTION WITH THE PRODUCT, WHETHER BASED ON CONTRACT, TORT, NEGLIGENCE, STRICT LIABILITY OR OTHERWISE, EVEN IF EIZO OR DISTRIBUTORS HAVE BEEN ADVISED OF THE POSSIBILITY OF SUCH DAMAGES. THIS EXCLUSION ALSO INCLUDES ANY LIABILITY WHICH MAY ARISE OUT OF THIRD PARTY CLAIMS AGAINST THE ORIGINAL PURCHASER. THE ESSENCE OF THIS PROVISION IS TO LIMIT THE POTENTIAL LIABILITY OF EIZO AND DISTRIBUTORS ARISING OUT OF THIS LIMITED WARRANTY AND/OR SALES.

Recycling Information

Recycling Information

This product, when disposed of, is supposed to be collected and recycled according to your country's legislation to reduce environmental burden. When you dispose of this product, please contact a distributor or an affiliate in your country.

The contact addressees are listed on the EIZO website below.

www.eizoglobal.com

For recycling information for customers in Switzerland, please refer to the following website.

www.swico.ch

Informationen zum Thema Recycling

Dieses Produkt muss gemäß den Vorschriften Ihres Landes zur Entlastung der Umwelt recyclet werden. Wenden Sie sich bei der Entsorgung dieses Produkts an einen Verteiler oder eine Tochtergesellschaft in Ihrem Land.

Die Adressen zur Kontaktaufnahme sind auf der unten angegebenen Website von EIZO aufgeführt.

www.eizoglobal.com

Kunden in der Schweiz entnehmen Informationen zum Recycling der folgenden Website:

www.swico.ch

Informations sur le recyclage

Ce produit doit être jeté aux points de collecte prévus à cet effet et recyclé conformément à la législation de votre pays, afin de réduire l'impact sur l'environnement. Lorsque vous jetez ce produit, veuillez contacter un distributeur ou une société affiliée de votre pays.

Les adresses des distributeurs sont répertoriées sur le site Web EIZO ci-dessous.

www.eizoglobal.com

Pour les clients en Suisse, veuillez consulter le site Web suivant afin d'obtenir des informations sur le recyclage.

www.swico.ch

Información sobre reciclaje

Este producto debe desecharse y reciclarse según la legislación del país para reducir el impacto medioambiental.

Cuando desee deshacerse de este producto, póngase en contacto con un distribuidor o una filial de su país.

Encontrará las direcciones de contacto en el sitio web de EIZO que se indica a continuación.

www.eizoglobal.com

Informazioni sul riciclaggio

Per lo smaltimento e il riciclaggio del presente prodotto, attenersi alle normative vigenti nel proprio paese per ridurre l'impatto ambientale. Per lo smaltimento, rivolgersi ad un distributore o un affiliato presenti nel proprio paese.

Gli indirizzi sono elencati nel sito Web EIZO riportato di seguito.

www.eizoglobal.com

Per informazioni sul riciclaggio per i clienti in Svizzera, consultare il sito Web riportato di seguito.

www.swico.ch

Återvinningsinformation

När denna produkt kasseras ska den hanteras och återvinnas enligt landets föreskrifter för att reducera miljöpåverkan.

När du kasserar produkten ska du kontakta en distributör eller representant i ditt land.

Kontaktadresserna listas på EIZO-webbplatsen nedan.

www.eizoglobal.com

Πληροφορίες ανακύκλωσης

Το προϊόν αυτό, όταν απορρίπτεται, πρέπει να συλλέγεται και να ανακυκλώνεται σύμφωνα με τη νομοθεσία της χώρας σας έτσι ώστε να μην επιβαρύνει το περιβάλλον. Για να απορρίψετε το προϊόν, επικοινωνήστε με έναν αντιπρόσωπο ή μια θυγατρική εταιρεία στη χώρα σας.

Οι διευθύνσεις επικοινωνίας αναγράφονται στην τοποθεσία web της EIZO παρακάτω.

www.eizoglobal.com

Сведения по утилизации

По истечении срока службы данного продукта его следует принести на сборный пункт и утилизировать в соответствии с действующими предписаниями в вашей стране, чтобы уменьшить вредное воздействие на окружающую среду. Прежде чем выбросить данный продукт, обратитесь к дистрибьютору или в местное представительство компании в вашей стране.

Контактные адреса можно найти на веб-узле EIZO.

www.eizoglobal.com

Informatie over recycling

Wanneer u dit product wilt weggooien, moet het uit milieu-overwegingen worden verzameld en gerecycled volgens de betreffende wetgeving van uw land. Wanneer u dit product wilt weggooien, moet u contact opnemen met een distributeur of een partner in uw land.

De contactadressen worden vermeld op de volgende EIZO-website.

www.eizoglobal.com

Informação sobre reciclagem

Este produto, quando o deitar fora, deve ser recolhido e reciclado de acordo com a legislação do seu país para reduzir a poluição. Quando deitar fora este produto, contacte um distribuidor ou uma filial no seu país.

Os endereços de contacto estão listados no website do EIZO, abaixo.

www.eizoglobal.com

Oplysninger om genbrug

Denne produkt forventes ved bortskaffelse at blive indsamlet og genbrugt i overensstemmelse med lovgivningen i dit land for at reducere belastningen af miljøet. Når du bortskaffer denne produkt, skal du kontakte en distributør eller et tilknyttet selskab i dit land.

Adresserne på kontaktpersonerne er angivet på EIZO's websted nedenfor.

www.eizoglobal.com

Kierrätystä koskevia tietoja

Tuote tulee hävittää kierrättämällä maan lainsäädännön mukaisesti ympäristön kuormittumisen vähentämiseksi. Kun hävität tuotteen, ota yhteyttä jälleenmyyjään tai tytäryhtiöön maassasi.

Yhteystiedot löytyvät EIZOn Internet-sivustolta.

www.eizoglobal.com

Wykorzystanie surowców wtórnych

Ten produkt po zużyciu powinien być zbierany i przetwarzany zgodnie z krajowymi przepisami dotyczącymi ochrony środowiska. Wyrzucając ten produkt, należy skontaktować się z lokalnym dystrybutorem lub partnerem. Adresy kontaktowe można znaleźć we wskazanej poniżej witrynie internetowej firmy EIZO.

www.eizoglobal.com

Informace o recyklaci

Při likvidaci produktu musí být produkt vyzvednut a recyklován podle zákonů příslušné země, aby nedocházelo k zatěžování životního prostředí. Zbavujete-li se produktu, kontaktujte distributora nebo pobočku ve své zemi. Kontaktní adresy jsou uvedeny na následující webové stránce společnosti EIZO.

www.eizoglobal.com

Ringlussevõtu alane teave

Keskkonnakoormuse vähendamiseks tuleks kasutatud tooted kokku koguda ja võtta ringlusse vastavalt teie riigi seadustele. Kui kõrvaldate käesoleva toote, võtke palun ühendust turustaja või filiaaliga oma riigis.

Kontaktisikud on toodud EIZO veebilehel järgmisel aadressil:

www.eizoglobal.com

Újrahasznosítási információ

Jelen terméket, amikor eldobjuk, az illető ország törvényei alapján kell összegyűjteni és újrahasznosítani, hogy csökkentjük a környezet terhelését. Amikor ezt a terméket eldobja, kérjük lépjen kapcsolatba egy országon belüli forgalmazóval vagy társvállalkozással.

A kapcsolat címei az EIZO alábbi weboldalán található felsorolva:

www.eizoglobal.com

Podatki o recikliranju

Ob koncu uporabe odslužen izdelek izročite na zbirno mesto za recikliranje v skladu z okoljevarstveno zakonodajo vaše države. Prosimo, da se pri odstranjevanju izdelka obrnete na lokalnega distributerja ali podružnico.

Kontaktni naslovi so objavljeni na spodaj navedenih spletnih straneh EIZO:

www.eizoglobal.com

Informácie o recyklácii

Pri likvidácii musí byť tento výrobok recyklovaný v súlade s legislatívou vašej krajiny, aby sa znížilo zaťaženie životného prostredia. Keď sa chcete zbaviť tohto výrobku, kontaktujte prosím distribútora alebo pobočku vo vašej krajine.

Zoznam kontaktných adries je uvedený na nasledovnej webovej stránke firmy EIZO:

www.eizoglobal.com

Pārstrādes informācija

Utilizējot šo produktu, tā savākšana un pārstrāde veicama atbilstoši jūsu valsts likumdošanas prasībām attiecībā uz slodzes uz vidi samazināšanu. Lai veiktu šī produkta utilizāciju, sazinieties ar izplatītāju vai pārstāvniecību jūsu valstī. Kontaktadreses ir norādītas zemāk minētajā EIZO tīmekļa vietnē.

www.eizoglobal.com

Informacija apie gražinamąjį perdirbimą

Šalinant (išmetant) šiuos gaminius juos reikia surinkti ir perdirbti gražinamuoju būdu pagal jūsų šalies teisės aktus, siekiant sumažinti aplinkos teršimą. Kai reikia išmesti šį gaminį, kreipkitės į jūsų šalyje veikiančią gaminių pardavimo atstovybę arba jos filialą.

Kontaktiniai adresatai nurodyti EIZO interneto svetainėje.

www.eizoglobal.com

Информация относительно рециклиране

При изхвърлянето на този продукт се предлага събирането и рециклирането му съобразно законите на вашата страна за да се намали замърсяването на околната среда. Когато искате да се освободите от този продукт, моля свържете се с търговския му представител или със съответните органи отговарящи за това във вашата страна.

Данните за връзка с нас са описани на следния Интернет сайт на EIZO:

www.eizoglobal.com

Informație referitoare la reciclare

Acest produs, când debarasat, trebuie colectat și reciclat conform legislației țării respective ca să reducem sarcina mediului. Când se debarasează de acest produs, vă rugăm să contactați un distribuitor sau un afiliat al țării respective. Adresele de contact le găsiți pe pagina de web al EIZO:

www.eizoglobal.com

معلومات عن اعادة التدوير

عند التخلص من هذا المنتج، من الضروري تجميعه واعادة تدويره وفقاً للقوانين المتبعة في بلدك لتقليل العبء المسلط على البيئة. عندما تتخلص من هذا المنتج، يرجى الاتصال بموزع أو طرف منتسب إليه في بلدك. عناوين الاتصال مدرجة في موقع ايزو EIZO ادناه على شبكة الانترنت.

www.eizoglobal.com

Gerı Dönüşüm Bilgisi

Bu ürünün, atılacağı zaman, ülkenizin çevre kirliliğinin azaltılması konusundaki mevzuatına göre toplanması ve yeniden değerlendirilmesi gerekmektedir. Ürünü atacağınız zaman lütfen ülkenizdeki bir distribütör veya ilgili kuruluşla temasa geçiniz.

İrtibat adresleri aşağıdaki EIZO web sitesinde verilmiştir.

www.eizoglobal.com

Removing the stylus battery (disposal)

The stylus includes a battery. When disposing of the battery, follow regional laws and regulations for appropriate disposal.

Attention

- Do not disassemble the stylus except for when disposing of the product.
- Cut the wires one by one and cover the cut part with tape to prevent it from coming into contact with other wires or metal parts.

- 1. Pull off the clip. (Tool to use: needle-nose pliers)**
- 2. Attach a USB charger or magnet to the power button and pull.**
- 3. Cut the wires. (Tool to use: diagonal pliers)**
- 4. Remove the tip by rotating it counter-clockwise.**

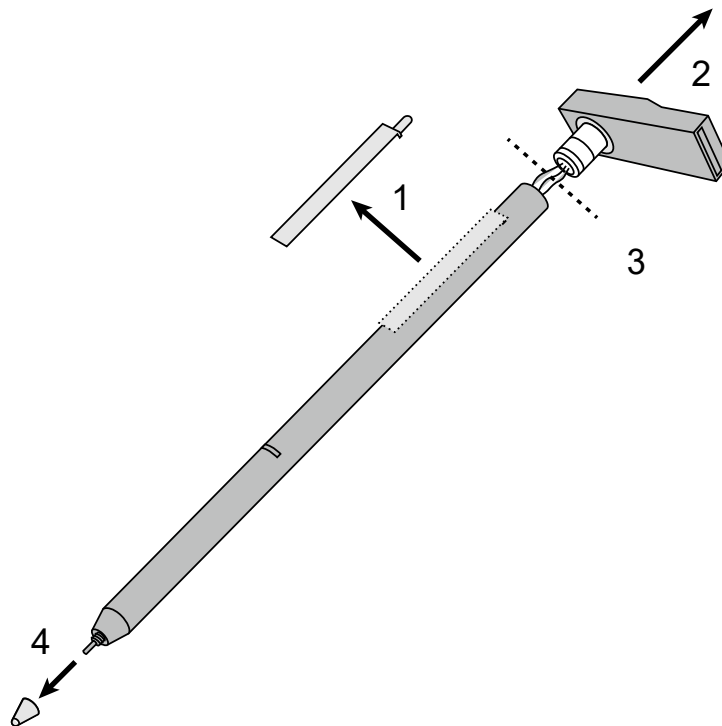

- 5. Remove a by rotating it counter-clockwise and then pull it out. (Tool to use: needle-nose pliers)**

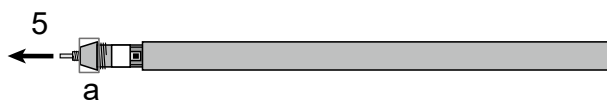

- 6. Cut the wires. (Tool to use: diagonal pliers)**

